



Truro-Colchester + You. Moving Accessibility Forward.

Draft Accessibility Action Plan for the Municipality of Colchester, Towns of Truro and Stewiacke, and Villages of Bible Hill and Tatamagouche, referred to as the Truro-Colchester Region.

Submitted by: reachAbility Association

2022



TABLE OF CONTENTS

1.0 Introduction

1.1 Summary Overview 4
 1.2 Territory Acknowledgment 5

2.0 Overview

2.1 Methodology 6
 A. Inclusion In Action 6
 B. RHFAC Lens 7

3.0 Standards & Benchmarks

3.1 Goods and Services 8
 3.2 Built Environment 8
 3.3 Information and Communications 8
 3.4 Awareness and Capacity Building 8
 3.5 Transportation 8
 3.6 Employment 8

4.0 Community Engagement

4.1 Summary 9
 4.2 Campaign 9
 A. Take the Survey 9
 B. Join the Discussion 10
 C. Show Us How 10
 4.3 Draft Engagement 10

5.0 Standards of Accessibility - Engagement Analysis

5.0 Preface 11
 5.1 Goods & Services 12
 5.2 Built Environment 16
 5.3 Information and Communication 21
 5.4 Awareness and Capacity Building 24
 5.5 Transportation 27
 5.6 Employment 29

6.0 Built Environment Accessibility Scan

6.0 Overview 31
 6.1 Community Halls and Centres, and Recreation Centres 33
 6.2 Municipality Building, Town & Village Halls 37
 6.3 Libraries 39
 6.4 Parks & Playgrounds 41
 6.5 Trails 42
 6.6 Fire Halls & Police Stations 43
 6.7 Sidewalks, Storefronts, Signs, Public Offices 44
 6.8 Tourist Attractions & High Traffic Areas 45
 6.9 Specific Built Environment Barriers 47

7.0 Timelines VS Priority Phasing	
7.1 Immediate	69
7.2 Short Term	70
7.3 Opportunity Based Recommendations	71
8.0 Plan Implementation	
8.1 About the Recommendations	72
8.2 Monitoring and Evaluation	72
Gratitude	74
9.0 Appendix	
9.1 Glossary of Terms	75
9.2 Stairs	77
9.3 Accessible Interior Routes	84
9.4 Parking	91
9.5 Ramps	96
9.6 Washrooms	105
9.7 Seating	121
9.8 Elevators	123
9.9 Accessible Boat Launches	129
10.0 Resources	
10.1 Funding and Community Based Resources	131
10.2 Training & Education	134

1.0 INTRODUCTION

1.1 SUMMARY OVERVIEW

Accessibility is a human right. The equal rights of a person are denied by making access difficult. As identified by Access by Design 2030, the first step towards achieving accessibility goals is through awareness and capacity building for the rights of persons with disabilities and/or people facing barriers to full participation. It is easy to get stuck in the old ways of doing things, which are rooted in patriarchal, colonial, ableist mindsets and structures. However, change is happening and we believe the Truro-Colchester Region will help set the bar for other Municipal regions across the province.

Nova Scotia has the highest rate of people identifying with having a disability in Canada. We have nearly one in three people who live with a disability, the most common of which are invisible, cognitive disabilities. There are many types of disabilities which include: physical, mental, intellectual, learning and sensory impairment, including episodic disability, that, in interaction with a barrier, hinders an individual's full and effective participation. The research and recommendations to follow address universal accessibility improvements for the Municipality of Colchester, Town of Truro, Town of Stewiacke, Village of Bible Hill, and Village of Tatamagouche and attempt to include the spectrum and experiences of all disabilities. For the purpose of this report, when referring to all areas at once we will refer to it as the Truro-Colchester Region. We also examined diversity and inclusion and its intersectionality with accessibility issues, and made recommendations that could lead to impactful changes in the Truro-Colchester Region.

The research and community engagement strategy for this report took place during the Covid-19 Global Pandemic, which further heightened access and equity issues for everyone. From the individuals and stakeholder groups we were able to connect with, we heard that accessibility issues were exacerbated due to increased poverty, social isolation, and lack of transportation, all of which further affected mental and physical health. The results of our community engagement are included throughout this report.

We would like to commend the Town's of Truro and Stewiacke, the Municipality of Colchester, and the Villages of Bible Hill and Tatamagouche on joining together as a region to address accessibility and inclusion for their communities as the Province of Nova Scotia begins its work towards the 2030 Access by Design: Achieving an Accessible Nova Scotia goal. For this report, we refer to Bill 59 also known as, the Nova Scotia Accessibility Legislation, including the recommendations put forth by the working groups for the Built Environment and Education Standards, and the Nova Scotia Post-Secondary Accessibility Framework created by the Council of Nova Scotia University Presidents and the Nova Scotia Community College. We also include and/or reference the Government of Canada's Accessible Canada Act, and the Rick Hansen Foundation Accessibility Certification built environment standards.

In order to involve as much of the Truro-Colchester community as possible we reached out to staff, stakeholder groups, and community members in all five regions to identify possible solutions to the future of access and inclusion in the Truro-Colchester Region. The responses were informed, rational and optimistic: all key components to building the foundation for an impactful Accessibility Action Plan.

We recognize that the Truro-Colchester Region, both jointly and in their individual areas, have a number of plans and goals in place. Our goal is to provide general recommendations for the Region, and specific recommendations per area, based on first-voice, community feedback, and legislation while acknowledging the work that has already been done. The solutions to achieving accessibility and inclusion will require resources, human and capital, but they have the capacity to be transformative for the Truro-Colchester Region and their respective communities. We hope that this report provides starting points to achieving goals, and delineating the steps in between to help you get there. It has been our pleasure to assist you with this work.

Regional Accessibility Committee's (RAC) Vision

“The Committee recognizes accessibility is a human right and that we have been mandated by the (Nova Scotia Accessibility) Act to become accessible by 2030 by removing barriers that restrict people from fully participating in society. To this end, the Committee is committed to establishing a long-lasting living environment that is inclusive and representative of the full range of human experience, across all public and private sectors and within each of the communities it represents.”

The RAC is committed to accessibility, diversity, equity and inclusion of all people regardless of ability, race, culture, gender, sexual identity and/or expression, family status, religion or age. To support this commitment reachAbility has been engaged as experts with first voice, lived experience and a robust knowledge of accessibility issues, best practices, legislative requirements, social equity and planning processes to ensure that a comprehensive framework will guide the development of accessibility initiatives and establish priorities across the Truro-Colchester Region.

1.2 TERRITORIAL ACKNOWLEDGMENT

Ancestral or Traditional Territory refers to the land occupied by First Nations people and their ancestors. The Truro-Colchester Region and reachAbility Association both reside within K'jipuktuk, the ancestral territory of the Mi'kmaq people. This territory is protected by the Treaties of Peace and Friendship, signed in 1752 between the Mi'kmaq, Maliseet, Passamaquoddy and the British Crown. This territory is known as Mi'kma'ki and was divided traditionally into seven districts: Kespukwitek, Sipekni'katik, Eskikewa'kik, Unama'kik, Epekwick aq Piktuk, Siknikt, and Kespek.

We acknowledge that our work and organizations are located within unceded and unsundered Mi'kmaq Territory that we all have a responsibility and accountability to uphold in the process of Truth and Reconciliation. We are all treaty people. There is much to do in terms of reconciliation and building meaningful dialogue, partnerships and opportunities to mend historical injustices and present day inequalities. We aim, through our work and our lives, to continue to better educate ourselves on what this means, and how we must use the many opportunities and privileges we are afforded to address the importance of place, equity, sustainability, peace and understanding. We celebrate diversity and believe that understanding the intersectionalities that occur within the Truro-Colchester Region is key to a truly inclusive culture.

2.0 OVERVIEW

2.1 METHODOLOGY

A. Inclusion In Action Lens

As an accessibility support organization, reachAbility Association helps guide businesses, organizations and public sector bodies through the process of creating an accessibility action plan compliant with government legislation, and in building leadership in accessibility, diversity and inclusion. The process of *Inclusion In Action* addresses accessibility through an inclusion and diversity lens driven by first-person voice and ensures alignment with the Province of Nova Scotia's "Accessibility Planning Toolkit for Municipalities". With extensive public consultation this creates an accessibility action plan to align with both Access by Design 2030 and the Nova Scotia Accessibility Legislation (Bill 59).

Consultation with client organization and identified groups

- Worked strategically through various meetings with the Regional Advisory Committee (RAC) to review the plan and methodology for the project; and discuss the critical goals as identified by the RAC.
- Reviewed strategic documents from the Truro-Colchester Region ie. policies, programs, services, practices and any additional documentation to assist in our understanding of the Truro-Colchester Regions efforts within accessibility, and through a data analysis we identified achievements, barriers and opportunities for improved accessibility and inclusion.

First-Person Voice

- Surveyed the community both online and in person to gain the perspective of lived experience.
- Engaged the public through three online sessions in addition to stakeholder group meetings and individual conversations with community members by phone, zoom and in person.
- Opportunities were provided, online and/or in person, for community participation in providing feedback on the built environment in the five areas within the Truro-Colchester Region. This was done through online mapping activities and in person conversation where barriers, successes and opportunities were identified throughout the Truro-Colchester Region.

Strategic Review

- Reviewed feedback from engagement sessions
- Revisited critical goals and compared them to the identified issues highlighted from engagement
- Reviewed the built infrastructure/environment of the organization's assets
- Based on the strategic review, created and presented a draft Accessibility Action Plan to the RAC and to the community through public engagement sessions, both online and in person, according to NS Health Guidelines.

Action Plan Delivery

- Reviewed stakeholder/public feedback from the draft accessibility action plan and determined, based on legislative requirements and the Municipality's goals, what to include in the final accessibility action plan
- Delivered the Truro-Colchester Region Accessibility Action Plan with deliverables including: prioritized timelines; phasing and resources.

Additional Recommendations & Resources

- Identified topics for continued learning for all organizational levels.
- Identified areas of opportunity for improved accessibility and inclusion through stakeholder partnership.
- Identified funding and grant opportunities to: offset Truro-Colchester Region costs with action plan implementation, and provide resources for businesses, organizations and individuals within the municipality to work towards a sustainable accessibility within the community.

B. Rick Hansen Foundation Accessibility Certification (RHFAC) Lens

(RHFAC) is a lens through which to assess accessibility. <https://www.rickhansen.com> RHFAC ensures people with disabilities have direct input into the vision and details of how to create truly inclusive places. RHFAC has a rating and certification process designed by people with disabilities to allow transparency, accountability and measurable data. RHFAC and Universal Design are interdependent. Universal Design is the design of public buildings, products and environments to make them accessible to all people regardless of age, disability or other factors. This ensures that human rights, compassion, democracy, and access are all at the forefront in the public realm. In order to create a sustainable, fully participatory community, Universal Design must be met to ensure access and inclusion.

Our team conducted an environment scan of the Truro-Colchester Region using the RHFAC lens. We did not conduct a National Building Code (NBC) review. It is important to note that RHFAC often has standards that are different from the NBC. While all aspects of a renovation or new builds must meet the NBC, meeting RHFAC standards would be ideal. We used some of the major principles of RHFAC as a guide to highlight where the needs for improvements are, as well as identify efforts and successes as per the scope of this Accessibility Action Plan.

3.0 STANDARDS & BENCHMARKS

In order to give feedback and assist in creating an accessibility action plan for the region we reviewed the programs, policies, services and built environments of the Region and addressed the following six standards of accessibility. As identified in the Access By Design 2030 framework, it is imperative to also address *Awareness and Capacity Building* to move forward and truly be inclusive, for this purpose we have included Awareness and Capacity Building along with the other legislative standards. These standards are based on the, currently in development, Nova Scotia Accessibility Act (Bill 59), and the Accessible Canada Act, as listed below:

3.1 Goods and Services

- Bill 59: standards for delivering and receiving goods and services may address how service providers interact with and are trained to serve persons with disabilities. This may include how persons with disabilities access goods and services, including the use of assistive devices.
- Accessible Canada Act: Service Design & Delivery: receive services that are accessible to all.

3.2 Built Environment

- Bill 59: standards in this area will address how to make buildings, streets, sidewalks, and shared spaces accessible to all. These standards may address gaps in current regulations.
- Accessible Canada Act: move freely around buildings and public spaces.

3.3 Information and Communications

- Bill 59: Requires institutions to ensure all Nova Scotians can receive and share the same information. Consider accessible formats (for example, braille, American Sign Language, or large print), accessible websites and technologies, and standards for communicating with persons with disabilities.
- Accessible Canada Act: Requires accessible digital content and technologies, barrier free spaces and services for people with communication disabilities.

3.4 Awareness and Capacity Building:

- Access By Design 2030: building capacity in accessibility and increasing awareness about the rights of persons with disabilities and barriers to participation.

3.5 Transportation

- Bill 59: public transportation and transportation infrastructure: standards in this area will help make it easier for everyone to travel throughout rural and urban Nova Scotia.
- Accessible Canada Act: barrier-free federal transportation network.

3.6 Employment

- Bill 59: standards in this area will support persons with disabilities in finding meaningful employment. The goal is to ensure equal access to employment for persons with disabilities.
- Accessible Canada Act: access to employment opportunities and accessible workplaces.

4.0 COMMUNITY ENGAGEMENT

In 2010, Canada ratified the United Nations Convention on the Rights of Persons with Disabilities (CRPD) committing to rid the country of barriers that prevent people with disabilities from fully enjoying their human rights. “Nothing Without Us”, the Accessible Canada Act, carries this commitment through legislation and ensures first-voice contributions. First-person knowledge is key to understanding the causes of inaccessibility and has guided our process in identifying barriers within the Truro-Colchester Region and offering recommendations to ensure equity, diversity and inclusion is achieved for all.

4.1 SUMMARY

The Truro-Colchester Region is a very diverse community. But, despite this diversity, the five communities that make up the region, share very similar needs and concerns. From Tatamagouche to Bass River, to Stewiacke and everywhere in between, members of the region love where they live. They are invested in the communities, in their lifestyles, and in the growth that is happening. However, they also share in the general consensus that they are disconnected. Disconnected from each other - lacking a sense of community and togetherness. And, disconnected physically because of the lack of connectivity between neighborhoods, communities and towns. In reviewing the engagement summary you will see that the community feels urgency when it comes to the need for pedestrian pathways, active transportation, and public transportation. We believe that through the implementation of the Truro-Colchester Region’s Accessibility Action Plan that progress can and will be made. For the purpose of providing feedback/findings for each accessibility standard, we have used the first-voice experiences collected through the **Moving Accessibility Forward** project. These first-voice experiences have also guided the recommendations offered throughout.

4.2 CAMPAIGN

In an effort to engage the communities of the Municipality of Colchester, the Town of Truro, the Town of Stewiacke, the Village of Bible Hill and the Village of Tatamagouche, reachAbility created micro social media campaigns titled *Area + You. Moving Accessibility Forward*. Additionally, there was a landing page created for the overall project, and individual pages for each respective areas’ campaign accessible on their own or through the project landing page which can be viewed by visiting www.reachability.org/regional-accessibility-plan

The targeted social media campaign was used to promote the project through Facebook, Instagram, and Twitter. The campaign reached over 40,000 individuals (saw the awareness campaign on their social media platforms); leading to 1465 organic clicks (people clicked through the ads to obtain further information about the campaign), and 1391 people visited the project landing page.

Due to COVID-19 public gathering restrictions, extended online, phone and small gathering or individual engagement sessions were offered in place of in-person public engagement options. The project's engagement process offered three methods for community members to get involved.

A) TAKE THE SURVEY

An online survey was created based on the accessibility standards and how they pertain to each of the five areas’ programs, services, built environment and communication. The survey was circulated to all current Town, Village and Municipal employees including their elected officials; online through the social media campaigns and as posted on the landing pages for each area; and physically at our pop-up event in Truro and most of the administrative offices throughout the Truro-Colchester Region.

The employee survey was customized to gain the perspectives of the **employee** when it came to employment for/with the Town, Village and/or Municipality. Otherwise, the employee and public surveys did not differ.

The public survey ran from December 2nd, 2021 to February 18th, 2022. Throughout this report, we provide summarized information to maintain anonymity for those who participated in the employee surveys. Of the survey results we received 62% of the respondents were from the Town of Truro; 12 % were from the Town of Stewiacke; 11% from the Village of Tatamagouche and 8% were from the Municipality of Colchester and the Village of Bible Hill respectively. We learned through further communication and feedback from community groups and administrative staff that this level of participation is typical with engagement campaigns, especially since the COVID-19 pandemic began.

B) JOIN THE DISCUSSION

Throughout January five virtual sessions were hosted inviting community members to *join the discussion* and have their voice heard to help inspire change in the Truro-Colchester Region as they work toward their inclusion and accessibility goals. Additionally, individual zoom meetings and/or phone calls were booked for stakeholder groups and anyone who could not attend the various virtual meetings. These sessions were moderated by Jessica Ward and Krista O'Connor of the reachAbility team and supported by ASL (American Sign Language) interpreters when requested.

The conversations throughout these sessions highlighted the gaps in accessibility and inclusion with the Truro-Colchester Region and identified the many strategies that have been or are currently being applied to remove barriers. We spoke with many disability and marginalized community support groups, individual citizens, youth with disabilities and their parents and community advocates.

C) SHOW US HOW

Community members were invited to *help us inspire change* by participating in an online mapping exercise. Provided were images of commonly used public spaces within the Municipality, Towns and Villages, and when available, floorplans or maps to accompany these built environments.

For each location, community members were asked to tell us:

- what is working
- what's not working
- to consider how they travel to, from, and around each built space, and;
- to share with us how they could envision things working better

By clicking through to the mapping exercise they could share with us success stories and areas needing improvement at the various locations, their valuable first-voice experience on the built environment and how it plays a part in the way they live, work, play or go to school, in the Region.

4.3 DRAFT ENGAGEMENT

An online survey was created based on the draft Accessibility Action Plan and the recommendations put forth. Respondents were asked to state whether they “Strongly agreed, Agree, Neither Agree or Disagree, Disagree or Strongly Disagree” with the recommendations presented. The survey was circulated throughout the Towns, Villages and Municipality; online through social media campaigns and posted on the project landing page.

We hosted an event at Civic Square in Truro, where we met with community members to discuss the draft plan over a cup of hot coffee. Panels presenting the plan graphically were created to assist in the discussion and paper surveys were on hand for community members to take with, or without our support.

5.0 STANDARDS OF ACCESSIBILITY - ENGAGEMENT ANALYSIS

PREFACE

“Under the Accessibility Act, municipalities, universities, and other organizations—including villages, regional libraries, and government agencies—may be prescribed as public sector bodies. (Prescribed means identified in the Accessibility Act General Regulations.) Once prescribed, these organizations—including municipalities and villages—must establish an Accessibility Advisory Committee and develop an Accessibility Action Plan.” (2019, Province of Nova Scotia)¹ As per the recommended format offered by the Province of Nova Scotia in the Accessibility Plan Toolkit for Prescribed Public Sector Bodies, the feedback from our engagement efforts has been summarized into seven components for each of the seven standards. Below we have provided a brief explanation/purpose of each component as identified in the aforementioned document.

Commitment: In this component, we will suggest a vision statement that aligns with the direction set out by the public sector body when it comes to inclusion, diversity, and equity.

Current Services Offered: The purpose of identifying the services currently offered by the prescribed public sector body is to provide the reader with a starting point. As a 3rd party organization, we do not know every aspect of the public sector bodies’ services, programs etc. We create a list based on information we are provided at the time of information gathering and/or what information is publicly available.

Overview: The overview component is meant to provide a summary of the feedback received, highlight specific points that were brought up through engagement and/or provide honourable mentions of key points.

Successes (What We Heard): An important part of the accessibility action planning process is to highlight the many successes or achievements that have been made to-date in identifying, preventing and removing barriers by/within the prescribed public sector body. This section provides a summary of what we heard from stakeholders throughout the project. This component does not include a comprehensive list of successes or achievements made by the organization.

Barriers (What We Heard): As above, this component will include a summary of what we heard from stakeholders and does not include a comprehensive list of barriers faced in every aspect of the organization. This component will focus on a compilation of the identified barriers that pertain to each of the seven standards as listed in Section 3 of this document.

Benchmarks: For the purpose of this report we have used the benchmarks component to offer suggestions for policy changes and/or adaptations based on the feedback received through our engagement process and the information provided by the Province of Nova Scotia about the Accessibility Act, it’s standards that are being developed, and the framework for implementation set out through the Access By Design 2030 Plan.

Opportunities/Recommendations: Prescribed Public Sector Bodies are obligated to ensure first voice and lived experience is considered throughout the implementation of the accessibility action plan. This component provides recommendations on how to take actionable steps toward achieving the benchmarks and the organizational commitments for each standard by engaging people with disabilities, diverse communities and other resources available in the community through organizations that work with and support members of equity seeking groups.

¹ reference for direct quote <https://novascotia.ca/accessibility/public-sector-bodies-toolkit.asp>

5.1 GOODS AND SERVICES

Commitment:

The Truro-Colchester Region aims to ensure all residents and visitors have equitable access to goods and services provided by the Municipality, Towns, and Villages.

Current Services Offered: The Truro-Colchester Region currently offers these goods and services:

Village of Bible Hill

- Maintaining parks, trails and playgrounds and responsible for the installation, maintenance and snow removal services of all sidewalks within the Village of Bible Hill.
- Hosts Village Commission and Accessibility Advisory Committee (AAC) meetings
- Provides emergency services through the Bible Hill Fire Brigade
- Offers recreational programming

Village of Tatamagouche

- Maintaining most parks, trails, and playgrounds and responsible for the installation, maintenance, and snow removal services of all sidewalks within the Village of Tatamagouche.
- Hosts Village Commission meetings
- Provides emergency services through the Tatamagouche Fire Department
- Offers recreational programming

Town of Stewiacke

- Maintaining most parks, trails and playgrounds and responsible for the installation, maintenance and snow removal services of most roads and sidewalks within the town limits of Stewiacke
- Maintains the Town of Stewiacke Water Utility
- Receives payments for property taxes and utilities
- Hosts Town Council meetings
- Formed the Regional Emergency Management Organization (REMO) with the Municipality of Colchester and Truro and provides emergency services through the Stewiacke Fire Department
- Offers recreational programming

Town of Truro

- Maintaining most parks, trails, and playgrounds and responsible for the installation, maintenance, and snow removal services of most roads and sidewalks within Truro's town limits.
- Maintains the Town of Truro Water Utility
- Receives payments for property taxes and utilities
- Hosts Town Council meetings
- Formed the Regional Emergency Management Organization (REMO) with the Municipality of Colchester and Stewiacke and provides emergency services through Truro Fire & Police Services
- Offers recreational programming

Municipality of Colchester

- Maintaining municipal parks, trails and playgrounds; installation and maintenance of all Municipal streets (blue street signs)², and providing snow removal for many roads in Bible Hill, Valley, Debert, Upper Onslow and Lower Truro.
- Maintains the water systems in Tatamagouche and Debert and sewer systems in Bible Hill, Brookfield, Debert, Great Village, Hilden, North River, Onslow, Salmon River, Tatamagouche, Truro Heights, and Valley
- Receives payments for property taxes and utilities
- Hosts Municipal Council meetings
- Formed the Regional Emergency Management Organization (REMO) with Truro and Stewiacke
- Offers recreational programming

² <https://www.colchester.ca/roads-and-driveways>

Survey Overview:

The majority of respondents identified privately owned businesses and services such as shopping or retail establishments; restaurants or bars; barber shops/hair salons and/or personal care services, and automotive services as the most frequented. (Average 85% across all responses) These services, for the most part, were also identified as the least accessible services. Of the town owned services identified as frequently accessed, public services (solid waste and leaf collection, by laws, taxes, utility bills, etc.) and libraries were at the top of the list (Average 59% across all responses). However, public transportation was highlighted across the board as the least accessible town owned service. Respondents stated they found it difficult to separate the accessibility of the service from the fact that without transportation, the services aren't accessible. When asked if they would share their experiences and opinions about how to increase the accessibility of their area, if able to, 63% of respondents said they would. It is notable to mention in Bible Hill and Truro the amount of citizens eager to share and help improve accessibility was in the 90% and 69% range, respectively. These numbers speak loudly to the fact that citizens have valuable input to shape the community and support in moving accessibility forward.

The vast majority of respondents to the surveys were residents with an average of 79% stating they live in the community they were completing the survey for. Additionally over half of all of the surveys were completed by individuals who self-identify belonging to at least one equity seeking group and also as being caregivers to a dependent (child, senior/parent, and/or dependent with a disability). This shows a diverse group of citizens in the Truro-Colchester Region that are not only open and ready to be engaged both from their own perspectives and those who are dependent on them, but who offer an opportunity to address the many intersectional barriers that come with belonging to one or more equity seeking groups. Of those identified, citizens identified as belonging to one or more of these groups: people with disabilities, women, LGBTQ2SIA, First Nations, African Nova Scotian, and Francophone.

Successes (What We Heard):

- The Village of Bible Hill formed an Accessibility Advisory Committee (AAC) independently from the Regional Accessibility Committee (RAC) in 2019 which has engaged community members and made positive changes to date.
- Recreation Departments in the area offer a variety of free and paid programs and services including many versions of free Equipment Loan Programs.
- The Bible Hill Village Office, both Town Halls and the Municipal Office Building all have some form of barrier-free access making their buildings physically accessible, if the person requiring the service is not doing so independently.
- Various areas within the Truro-Colchester Region already work together on multiple regional plans, projects and services. These partnerships and willingness to support each other will be instrumental in implementing the phases of this plan.
- All communities, with the exception of Tatamagouche, have clearly posted hours and open door policies when it comes to accessing the services within their administrative buildings, and citizens are aware of this and report doing so regularly.

Barriers (What We Heard):

- The parks, playgrounds and outdoor spaces don't provide options for all ages ie. senior friendly exercise equipment, adult sized accessible swings, family engaging activities for year round use.
- There is a lack of inclusive programming, events and services offered by the regions' Parks and Recreation Departments. Gaps in services include providing equal access to competitive sports and recreational programs for low-income families; adaptive equipment included in the Equipment Loan Programs; guided programs using the trails and parks throughout the region, and affordable access to recreation centres for physical activity during the winter months.
- There aren't any community building activities to bring community groups and organizations together to bridge the gaps in services and communities.
- The downtown cores of each area within the region do not provide access to the essential services needed for their respective communities.

- Groceries and fuel are astronomically priced in the Villages within the region, weighing heavily on those who are low-income and/or on fixed incomes. The much cheaper options, in Truro, are not accessible without transportation.
- The operating hours of many necessary services like libraries (internet access) and recycling and solid waste facilities makes it difficult for many to access the necessary services.

Benchmarks:

- **Ensure services required by residents and visitors are accessible to them.** This includes being physically accessible at publicly accessed spaces like parks, playgrounds and trails.
- **Ensure equal opportunity for play for everyone.** Consider offering “Play Boxes” at various park locations that provide free, adaptive play items to promote unstructured recreation activity.
- **All staff to be trained in diversity and inclusion so everyone is ready, willing and able to provide inclusive services.** Some employee groups will require more in-depth training depending on the services they provide: inclusive customer service for retailers; disability awareness for recreational staff; accessible communication for communications staff; unconscious bias for senior leaders. Training should be compulsory for all groups.
- **Ensure adequate staffing for roles that provide support.** People with disabilities and/or those who experience barriers to full participation cannot go without because service providers do not have the capacity or are not provided what they need to adapt ie. adequate staffing for day camp and recreation programs in order to accommodate children with disabilities.
- **Promote acceptance by implementing an accessibility policy for all new business/builds or renovations.** Shopping and retail establishments were identified as the most accessed and the least accessible spaces which highlights the need for an accessibility policy for businesses. Create a culture of acceptance by providing incentives (tax cuts for certain time periods) for those businesses and service providers who abide by the policy instead of fining for non-compliance.
- **Ensure equitable access to all public services, in all regions.** Extend the hours for public services like libraries (providing internet access), solid waste, recycling, bill payments etc by extending into evenings/mornings or weekends. For the Balefill Facility, an after hours drop off spot would be sufficient.
- **Creating opportunities for community building by hosting events that bring communities together.** Bridge the gap that exists between community groups and the community as a whole by kickstarting an annual event like a mural festival similar to the [Town of Kentville](#) beautifying the community and increasing representation through art; or celebrate diverse cultures with a multicultural festival like the [Dartmouth Waterfront](#) event.

Opportunities/Recommendations:

- Work with disability support agencies and agencies that support equity seeking groups within the Truro-Colchester Region to begin to build capacity and awareness around diversity, inclusion and accessibility for all. This should include implementing inclusive and culturally supportive programming with partners support and guidance.
- Create a standard for accessible service delivery that holds accountable all providers who work within the Truro-Colchester Region until the Province develops a government-wide accessible customer service policy as identified in Nova Scotia’s Accessibility Plan (2018-2021).
- Partner with Nova Scotia Works offices in the region to gather funding resources, support and training information to provide to employers in the region who want to improve their inclusive hiring practices.
- Become a wealth of knowledge for your communities by seeking out resources available through support organizations in the region. For example: Autism Nova Scotia is able to offer Autism Camps in Truro for free thanks to their fundraising efforts.

Indicators:

The Municipality, Towns and Villages will monitor the following items in regard to Goods and Services provided:

- The percentage of Municipal, Town, and Village meetings live-streamed and/or recorded with American Sign Language (ASL) interpretation and closed captioning provided.
- The number of complaints received in regard to inaccessible Goods and Services within the Municipality, Towns and Villages.
- The number of staff who have completed inclusive and accessible customer service training.
- The number of “play boxes” placed at local parks and playgrounds for access to free, unstructured play.
- The number of requests from businesses to receive financial assistance or resource related support for increasing accessibility and inclusion of their businesses.

5.2 BUILT ENVIRONMENT

The following section refers to feedback received from the community focused on Built Environment.

Commitment:

The Truro-Colchester Region aims to exceed minimum accessibility standards when, and if possible, by making all buildings, streets, sidewalks, and shared spaces accessible to all.

Village of Bible Hill

Current Offerings: The Village of Bible Hill is currently responsible for the installation, maintenance and snow removal services of all sidewalks within the Village of Bible Hill, and the following listed entities:

Parks and Trails:

Truro-Bible Hill Off-Leash Park
Reston Drive Park
Teakwood Court Park
Pat Mahaney Mountain Bike Trail
Bible Hill Recreation Park
Airport Park
Holy Well Park
Poplar Drive Park
Farnham Road Park
Meadowland Park
Village Court Park
Armstrong Ave Park
Murdock Park

Buildings:

H. Douglas Boyce Village Hall
Village Commission Hall

Other:

Splash Pad
Multi Purpose Field
Walter Langille Gazebo

Village of Tatamagouche

Current Offerings: The Village of Tatamagouche currently owns, operates, and maintains all sidewalks and the following listed entities:

Parks and Trails:

Paterson Wharf Park

Buildings:

Maintenance Shed

Other:

Campbell's Marina

Town of Stewiacke

Current Offerings: The Town of Stewiacke currently owns, operates, and maintains all roadways, sidewalks, crosswalks, and the following listed entities:

Parks and Trails:

John Crawford Trail
Stewiacke River Country Trail
Dennis Park
Stewiacke Skate Park
Stewiacke Recreation Park
Off-leash Dog Park

Buildings:

Public Works Building
Stewiacke Branch Library
East Hants Sportsplex
Stewiacke Town Hall

Town of Truro

Current Offerings: The Town of Truro currently owns, operates, and maintains all roadways, sidewalks, crosswalks, and the following listed entities:

Parks and Trails:

Victoria Park
Tim Hortons Skate Park
Riverfront Park
Gero Walkway
The Railyard
Kiwanis Park
Stan 'Chook' Maxwell Memorial Park
Herb Peppard Park

Buildings:

Water Treatment Plant
Truro Town Hall
Douglas Street Recreation Centre
Truro Library

Other:

TAAC Grounds & Clubhouse
Soccer and Baseball Fields
Civic Square

Municipality of Colchester

Current Offerings: The Municipality of Colchester currently owns, operates, and maintains all roadways, sidewalks, crosswalks, and the following listed entities:

Parks and Trails:

Five Islands Lighthouse Park
Fundy Discovery Site
Nelson Memorial Park
Cobequid Trail
Debert Recreation Park
Hilden Recreation Park
North River (Leo Blair Memorial) Ball Field
Valley Recreation Park
Rocky Ridge Park
Stewiacke River Park

Buildings:

Rath Eastlink Community Centre
Colchester Wastewater Facility
Municipality of Colchester Building
Colchester Historeum
Don Henderson Memorial Sportsplex
Truro Legion Stadium

Other:

Balefill Facility

Survey Overview:

When addressing **public built environments** the majority identified public grounds/roads and open spaces (79%), crosswalks and sidewalks (75%), and parks and trails (64%) as the most frequented built spaces, however it is notable to mention #4 were social venues or restaurants/bars (63%). Furthermore, social venues or restaurants/bars were identified as the least accessible (41%), followed by public grounds (33%) and crosswalks and sidewalks (30%).

When asked which **Village/Town or Municipality owned built environments** they frequented most, the individual results were as below:

- Truro: Victoria Park (69%), Farmer's Market (68%) and the Truro Library (51%). Least accessible spaces for Truro were Victoria Park (33%), Farmer's Market (24%), and 33% said "other", those responses focused on sidewalks, lack of public washrooms and Ecole Acadienne.
- Tatamagouche: Farmer's Market and North Shore Recreation Centre (57%) and the Tatamagouche Library (43%). When asked about the least accessible spaces in Tatamagouche, all responses pertained to accessible parking.
- Stewiacke: Dennis Park (57%), Stewiacke Recreation Park and Town Library (43%). Least accessible spaces were a tie, Town Hall, Public Works Building, Library and John Crawford Trail.
- Bible Hill: Bible Hill's Recreation Park and "other" noted as Cobequid Trail, and Scotia Pool. When asked about the least accessible village owned spaces responses focused on the fact that everything is inaccessible without access to transportation.
- Colchester: Rath Eastlink Centre (56%), MOC Building (44%) and Balefill Facility (33%). Least accessible of the Municipality owned spaces, 44% commented expressing their concern over sidewalks and safety, otherwise the MOC building and Debert Airport were tied at 22% each.

Successes (What We Heard):

- There are accessible washroom facilities at both the Bible Hill Recreation Park and Victoria Park.
- There are some sensory rooms in rec centres and other large community spaces which are helpful for welcomeness/acceptance and a space for “calming down” but it’s not enough.
- The Rath Eastlink Centre has many great accessibility features like: barrier free access to rinkside seating, barrier-free access to the pool, an adult changing table in one of the changing rooms, an elevator accessing both levels, and more.
- The libraries in the Truro-Colchester Region have all been, or have plans to be, renovated to include aspects of accessibility and inclusiveness. There are plans to build a new, accessible Stewiacke Library
- The Bible Hill Recreation Park has had accessibility updates to the playground and splash pad areas.
- There are a number of well groomed trails in the region with appropriate wayfinding and rest areas.

Barriers (What We Heard):

- Amenities like post office boxes, resting areas, ATM machines, and garbage receptacles are not logically placed, easily accessible and/or not prevalent enough throughout the community. Many of these amenities have been removed to minimize the spread of COVID which creates more inequity and accessibility barriers.
- The Municipality of Colchester Office Building does not have an accessible main entrance.
- The Truro Amateur Athletic Club grounds building, which is used for many community events, is three levels and only accessible on the main level.
- Well maintained, public, accessible washrooms are not adequately available throughout. They need to be at every park, trail, playground and heavily traveled areas. Covid has highlighted this issue in all regions with public washrooms usually locked.
- Pedestrians can’t make informed decisions on how to get where they need to go. Sidewalks do not provide connectivity between town amenities, schools, parks etc and there is no consistency in installation, maintenance and snow removal among sidewalks, crosswalks, streets or pathways in any area.
- Parks, playgrounds and trails aren’t accessible. Specifically, there isn’t an accessible trail to the falls at Victoria Park and the playground platform and equipment are not accessible or inclusive to all who want to use them.
- There a number of priority #3 roads in the region which are last on the list for snow removal and with winters like 2022, often don’t get cleared before the next storm. Lack of all season roads causes issues for accessing employment, essential services and social interaction.
- There is insufficient accessible, affordable housing. Where there are housing developments, they are built far from the downtown core and essential services like hospitals and grocery stores.
- Not enough lighting for pedestrian pathways (sidewalks, crosswalks, trails). There are many dark, unsafe zones, specifically mentioned in Stewiacke.

Benchmarks:

- **Create a regional standard for crosswalks and sidewalk installation and maintenance.** A regional standard will ensure accessible, safe, connectivity between amenities and areas of the community. The standard could have levels of installation and maintenance similar to the snow removal plan whereas heavily trafficked crosswalks and sidewalks within a certain radius of each “downtown core” would follow one plan; the connectivity of this “downtown core” to a certain radius outside of it could follow another, and new residential developments could have another. Each plan would follow the same structure and include the same accessibility features. Plan to start, and throughout the next 8 years, fix, replace and install to meet the plan’s requirements. Include tactile indicators, contrast, audible and visual indicators, use automatic signals instead of manually pressed, and lengthen the time for the crossing signal to allow for safe passage.
- **Create a minimum standard, or update an existing standard for playgrounds.** Playgrounds offer free opportunities for physical activity and need to be inclusive and engaging of all age levels. The standard should include: cork surface below all play structures, accessible swings (including ones for adults), adaptive equipment, ground-level access, accessible parking (or at a minimum safe streetside parking with an accessible access point to the play area), accessible seating and accessible washrooms. (see Accessible Playground examples in appendix)
- **Increase wayfinding and use adequate signage to locate essential amenities and identify accessibility within the built space.** Wayfinding and adequate signage enable the users to make informed decisions. (ie. ATMs can be found here and here; this trail is fully accessible; this park is accessible physically with support and does not have sensory specific equipment; only the bathroom at X point is fully accessible) This ensures that accessibility features are found and maximized and dignity is maintained by everyone.
- **Consider accessibility and adhere to the Built Environment standards.** All town, village and municipal buildings need to not only have physically accessible entrances, but accessibility needs to be met throughout the entire built environment, including furniture, and fixtures. This needs to be a priority when the Truro-Colchester Region renovates, acquires or builds any of its facilities. Model this standard level of accessibility and provide incentives to privately owned businesses/service providers who strive to meet the same standard as mentioned in Goods and Services.
- **Ensure public water access in the region's parks have accessible water frontage/access** (falls, rivers etc.). Safety and accessible, equitable access needs to be considered. For example, river access in Stewiacke River Park; Tatamagouche along the river, and at beaches in the region. The work done to increase equitable access at Peggy’s Cove is commendable. This level of inclusivity should be aspired to with all new projects **See Appendix for resources for an accessible floating dock for kayaking.**

Opportunities/Recommendations:

- Engage disability focused organizations and/or community members with disabilities in the planning and design of new built environments or renovations to existing structures and ensure Universal Design is considered when doing so.
- Share ideas, resources and best practices among the villages and towns ie. H.Douglas Boyce Hall and Bible Hill Fire Brigade hall recent updates.
- Promote an event whereby elected officials and/or administrative staff tour the community with people with disabilities using various mobility devices; blindfolded with assisted guides, and/or wearing noise canceling headphones to try and gain new perspectives and raise awareness.
- Consider sensory barriers in public spaces and at public events. Low sensory times are helpful and increase welcoming and acceptance; sensory rooms are important in recreation centres and other large community spaces, but they aren’t enough. Consider pieces of parade routes where the parades will be silent; encourage lower lighting, and reduce the need to wait in crowded lobby areas when possible.

Indicators: The Municipality, Towns and Villages will monitor the following items in regard to the Built Environment in their areas:

- The number of locations with accessible wayfinding and equitable access.
- The distance of accessible sidewalks.
- The number of accessible crosswalks that meet provincial standards.
- The number of accessible parking spaces that meet provincial standards
- The number of Municipal, Town or Village owned buildings that have accessible main entrances.
- The number of Municipal, Town or Village owned buildings and built space that have fully accessible public washroom facilities.
- The number of Municipal, Town or Village owned playgrounds that have equitable access for everyone.

5.3 INFORMATION AND COMMUNICATION

Commitment:

The Truro-Colchester Region aims to provide all communication in accessible formats ensuring that everyone can receive, understand and share the information provided by the Municipality, Towns and Villages. This may include but is not limited to communications policies, procedures and practices in order to facilitate accessibility and adapting an institutional standard.

Current Offerings:

The towns, villages and the municipality currently send important information in printed form to those who receive bills through the mail; post information on public bulletin boards throughout their area when available; provide digital and physical versions of newsletters to the community and post announcements and event information on their websites and social media platforms.

Overview:

According to survey results, 100% of respondents have daily access to the internet whether at home, work, school or at their local library. 88% of respondents access information from their respective communities through social media platforms, other frequently used forms of information communication were local radio, the individual Town/Village/Municipality websites and newsletters, and through local libraries.

A list of services, programs, events and publications were compiled that were found for each of the Towns, Villages and the Municipality and respondents were asked to select all they are aware of. The results are as follows. On average the awareness of:

- Social Media and Websites - 76%
- Community Newsletters - 64%
- Events - 64%
- Initiatives, Projects and Committees - 35%
- Programs - 30%
- Regional Accessibility Committee - 14%

A few key points to mention - the Municipality of Colchester had the highest awareness percentages - 71% are aware of the Cobequid Trail Run, the Mass Casualty Commission and the Municipality of Colchester Newsletter. The methods used to promote and inform about these events and initiatives should be duplicated for all programs and services. It was also mentioned that there are roadside rentable signs “everywhere” and these would be “well used to inform about important dates and events”.

Successes (What We Heard):

- There’s an ongoing partnership between Colchester and Cumberland Counties with Develop NS to provide 97% coverage of reliable internet
- The Town of Stewiacke role models great wayfinding for their numerous trails and for important town amenities and destinations with their town maps that are available throughout the town, both posted and for someone to take with them. These signs provide informed decision making for the user, highlight essential information like route length and quality, as well as accessibility features.
- The Bible Hill Fire Brigade Electric Board is a great resource for community announcements.
- It is great to see that the directions to Victoria Park throughout the Town of Truro have increased.
- There has been an improvement in the placement of signage throughout, having signs at eye level increases their accessibility.
- The Cobequid Trail entrances have great signage with contrast and large font.

Barriers (What We Heard):

- Information is not translated into other languages, more french and other options are needed
- There needs to be a map that highlights accessible spaces in each region, or adequate signage with accessibility features and/or limitations at entrances of built spaces.
- Websites are not kept up to date, specifically Tatamagouche. This needs to be prioritized.
- ASL is not provided at public events or in council meetings.
- Reliable, high speed and affordable internet are barriers in all areas. Due to the infrastructure required for rural internet, it is typically priced outside the means of most community members.
- Inconsistent signage and wayfinding everywhere.
- Newsletters are crowded and use small print. Digital newsletters and other correspondence (posters etc) need to be made available in plain text, or with descriptions for all images/non-text elements.
- Advertising of important events etc is not being found in media that is consumed by the community, “we don’t all listen to Truro radio”, and the information isn’t provided in a timely manner to enable us to participate, it is “always too late”.

Benchmarks:

- **Ensure all communication is delivered in accessible formats and can support the use of assistive technology.** This includes all Town, Village and Municipal websites, social media communications including image descriptions and ASL interpreting and captioning for video content, and physical/written text as means of communication should include plain language options, the availability of audio transcriptions, and ASL interpretation. **Truro, Colchester, Stewiacke, Bible Hill and Tatamagouche should and can aim to exceed the WCAG 2.1 standards.**
- **Create communications policies that protect and work for all stakeholders.** Software and platforms used for program and service delivery need to be accessible to the end-user. Listen to what employees and community members are saying and make changes to policies to allow for **ease of accommodations.** For example Zoom vs Microsoft Teams, Youtube vs Zoom for Council meetings, etc.
- **Re-evaluate the various systems and platforms being used for reservations, bookings, bill payments etc.** Ensure all platforms and systems can be easily used from mobile devices and tablets, and when possible, have them reviewed by people with differing abilities to ensure they work with assistive technology.
- **Create a standard for communication that ensures nothing is emailed, mailed, posted or otherwise if it does not meet certain standards for accessibility and need.**
- **Ensure that providers can confirm their product/service meets a minimum of WCAG 2.0 standards when procuring IT/Software.**
- **Create an accessible signage standard.** Be sure to identify font style, size, contrast, logo placement, and the use of universally recognized icons for accessibility features.
- **Ensure clear, easy to read, eye-level floor plans/maps are available for all built space entrances.** Providing wayfinding for both indoor and outdoor built environments supports informed decision making. These can also be made available online if and where applicable.

Opportunities/Recommendations:

- Involve the Truro-Colchester Region Accessibility Advisory Committee in guiding these policies. The committee consists of staff as well as knowledgeable community members who have the capacity to lead these conversations.
- Available technology exists for interactive, accessible digital boards where information can be shared, wayfinding is made accessible, events, business hours, and contact information can be readily available. Consider a digital interface where information can be provided and updated in real-time. It could become an asset to everyone, especially visitors.
- Offer staff training to learn how to create accessible documents. Everyone who is responsible for creating documents and/or any form of communication can be equipped with the knowledge and capabilities to create them in all formats.

Indicators: The Municipality, Towns and Villages will monitor the following items in regard to Information and Communication:

- Percentage of documents/communications completed with accessible formats (image descriptions, ASL interpretation, closed captioning, plain text etc)
- Number of staff trained in creating accessible documents.
- Percentage of signs produced with accessible fonts, contrast, and the use of universally recognized icons depicting accessibility features.

5.4 AWARENESS AND CAPACITY BUILDING

Commitment:

The Truro-Colchester Region aims to foster a culture of accessibility, diversity and inclusion by facilitating the prevention and removal of barriers to participation for everyone. The Truro-Colchester Region will do so by promoting awareness throughout the Municipality including the Towns and Villages about the importance of accessibility, diversity and inclusion.

Village of Bible Hill

Current Offerings: In the summer of 2019, the Village of Bible Hill rebranded based on community feedback from “A Progressive Community” to “Plant Your Roots”. Loosely based on a barley spike, which symbolizes agriculture, one side of the new logo icon is a set of houses which represents family, lifestyle and neighbourhoods; with the other side being leaves, which represents recreational spaces, agriculture and ties back to the tagline. ‘Plant Your Roots’ references the mission and values of Bible Hill through the idea of planting a seed and becoming part of something bigger.”³ In 2020 the Village of Bible Hill established an Accessibility Advisory Committee of community members and council to address the prevention and elimination of barriers for all members of the community.

Survey Overview: Half of those surveyed said they “feel included and represented within the Village of Bible Hill.” None of those surveyed online or in-person referenced receiving messaging about accessibility, diversity or inclusion. There was concern that messaging from the Village is not available on all mediums, mentioning that the weekly paper and/or Village newsletters are not the best method to reach the masses. 90% of those surveyed want to provide input if given the opportunity and offered their contact information for further feedback with the draft report. 70% identify as belonging to one or more equity seeking groups, additionally, 70% of respondents do not identify as people with disabilities - indicating there are a large number of diverse groups within the community who as mentioned above, are not seeing themselves represented within their community.

Municipality of Colchester

Current Offerings: The Municipality of Colchester spans a hundred communities in the centre of Nova Scotia. It’s values include being visionary, collaborative, responsible and engaged. The Municipality says they’re a progressive government focused on “preserving the region’s strong cultural roots, investing in strategic infrastructure and economic development initiatives, and improving quality of life for the citizens it serves.” Their new logo paired with the slogan “Be Centred Here” is said to “encapsulate the essence of Colchester’s brand”, promote the Municipality’s central location, and point to Colchester’s “unparalleled quality of life”. Colchester prides itself as a place to live an affordable balanced lifestyle and a welcoming, family-focused community that is diverse not only in culture but also with natural beauty.

Survey Overview: One third of those surveyed said they “feel included and represented within the Municipality of Colchester.” Equally so, thirty percent said they “did not feel included and represented within the Municipality of Colchester” and another thirty percent chose to comment rather than answer. 67% of those who provided feedback on the survey want to be engaged further. 78% of respondents live in the Municipality, additionally, 78% are aged 41 or older. 67% do not identify as a person with a disability, and 67% state they have dependents to care for (children, people with disabilities and/or parents/seniors).

Town of Stewiacke

Current Offerings: The Town of Stewiacke is the third largest town in the province, geographically, and is known for sitting “halfway between the Equator and the North Pole”. It’s motto is “Strength, Prosperity, and Growth”, and based on communication with the Town administration, they are positioned to experience their largest growth in history over the next few years.

Survey Overview: Seventy-one percent of those surveyed said they “feel included and represented within

³ reference <https://www.biblehill.ca/aoth-2019/302-aoth-september-2019/file>

the Town of Stewiacke.” Of those who responded, many offered their personal information for further feedback and used this opportunity to provide thoughts about the physical accessibility of the streetscapes (sidewalks, crosswalks, roads and traffic safety). None of the comments in this section of the survey mentioned feeling, or not feeling included or supported, by Stewiacke. 93% of respondents said they live in Stewiacke, 51% of respondents also identify as belonging to one or more equity seeking groups, only 35% of those surveyed identified specifically as a person with a disability.

Village of Tatamagouche

Current Offerings: The Village of Tatamagouche is located on the Northumberland Strait which is where their slogan - Meeting of the Waters - is derived. The village is known for its “small town” vibes and is a hot spot for tourism.

Survey Overview: Two-thirds of those surveyed said they “feel included and represented within the Village of Tatamagouche”. 14% of respondents said they “don’t feel included and represented within the Village of Tatamagouche” and, just under 22% chose to respond with written comments instead. Many offered their personal information for further feedback and used this opportunity to provide thoughts about the barriers they have faced within Tatamagouche when it comes to feeling welcomed within the community. The respondents shared feelings of not being a part of the “clique” and “feeling notes of racism and prejudice”. 57% percent would share their experiences and opinions if they had the ability to do so. 29% of the respondents identified as belonging to equity seeking groups. 71% of respondents said they live in Tatamagouche, many of whom identified as being retired with 72% of respondents 51 years or older.

Town of Truro

Current Offerings: Truro is located in the heart of Nova Scotia, and has been called one of the best places to live in all of Canada by Chatelaine Magazine. There have been a lot of new essential services added to the Truro area like the Colchester East Hants Health Centre, the Rath Eastlink Community Centre, and the new Colchester East Hants Library, it's a growing bustling community and known as the “Hub of Nova Scotia”.

Survey Overview: Just under half of those surveyed said they “feel included and represented within the Town of Truro”, the remainder of the survey respondents said they either “don’t feel included and represented within the Town” or chose to respond with a written comment instead. 87% of respondents said they want the opportunity to share their opinions and many offered their contact information for further feedback. Many took this opportunity to provide their thoughts and shared similar sentiments - “I believe we are making progress, but there is a long way to go” or “It can be amazingly progressive or oppressive.” There were concerns about the need to include the growing francophone community in Truro, while also demanding more engagement in projects such as this one, claiming “People want to be a part of making this community better, but they are never truly given the opportunity.” “The Town plays an important part in role modelling inclusion.” A regular Town Hall meeting would be a good place to start to spread the word and engage the diverse community and ask them what needs to be done.

Successes (What We Heard):

- There is now Francophone representation with the Town of Truro staff which the community is happy about
- The Library has sensory toolkits that citizens can access.
- The Truro Council Chambers and Town Hall offices are full of diverse artwork creating a welcoming environment for all.

Barriers (What We Heard):

- There’s a lack of safe spaces for equity seeking community groups and a feeling of generally being unsafe within the Municipality. Additionally, there aren’t any activities to specifically engage equity seeking groups like immigrants and/or the LGBTQ2SIA community.
- The community doesn’t see diverse representation in the region's public facing services.

Additionally, there is a strong group of people committed to equity in the Region but those voices aren't represented in Council or Administration.

- Awareness has felt limited to physical accessibility only. The community is not accessible in a sensory way and there is limited additional support for those with sensory needs.
- The Equity & Diversity Committee seems to be very quiet or has been discontinued.

Benchmarks:

- **Create a plan for learning for all levels of staff at the Truro-Colchester Region** that includes anti-oppression training, emotional intelligence and/or unconscious bias, terminology, legislation, the ease of accommodation, accessible language etc.
- **Make accessibility a financial priority.** Add it to the budget and plan how it will be addressed. Accessibility is doable but it takes planning, time and cooperation.
- **Diversity cannot be a number measurable - it has to be a feeling of acceptance and welcome.** The built environment needs to foster the feeling of belonging.
- **Create opportunities for all people with disabilities.** Create equity hires or committee positions to ensure inclusion of not only people with disabilities but members of all equity seeking groups.
- **Appoint a Director of Compliance or designated role to focus on accessibility compliance.** The Province of Nova Scotia will be creating compliance measures for the accessibility legislation, but, this framework has not yet been developed. In the meantime, create a designated role to review and reassess progress to date.

Opportunities/Recommendations:

- Partner with agencies that support people with disabilities on a regular basis for events, programs, and learning opportunities and do so in the public's eye. Promote the partnerships and encourage the Truro-Colchester community to join in.
- Celebrate the diversity of the Truro-Colchester Region.
- Encourage employees and/or the RAC to get involved in the various working groups with the Province of Nova Scotia to help build the standards that will guide all goods and services within Truro-Colchester Region.
- Consult with agencies and organizations supporting people with disabilities and/or people from marginalized communities when making decisions and/or creating policies to ensure they are being done without bias, and with full consideration and engagement of these communities.
- Increase awareness about mental health and intersectional barriers like food and financial insecurity, affordable housing, support for single parents by partnering with service agencies and promoting messages and events of awareness.

Indicators: The Municipality, Towns and Villages will monitor the following items in regard to Awareness and Capacity Building:

- Percentage of Municipal, Town and Village staff that receive training in anti-oppression, unconscious bias and/or unconscious bias, terminology, legislation, the ease of accommodation, accessible language etc.
- The number of people with disabilities and members of other equity seeking groups hired by the Municipality, Towns and Villages.

5.5 TRANSPORTATION

Commitment:

The Truro-Colchester Region aims to make it easier for everyone to get where they need to go throughout the Municipality, Towns, and Villages and will continue to discuss options for increased accessibility and the removal of transportation barriers for residents and visitors.

Current Offerings:

The Truro-Colchester Region does not currently own/operate any public transportation businesses or systems with the exception of the Colchester Transportation Corporation Limited (CTCL) owned by the Municipality of Colchester. The CTCL offers “dial-a-ride” taxi-like services; charter services and regular services for employment or educational purposes throughout the Municipality.

Overview:

The three main responses when asked about how community members travel in the Truro-Colchester Region are: by car (90%), walking (78%) and cycling (49%). None of the respondents identified public transportation as their main source of transportation. However, they do say that it is their main barrier, because, as quoted from the survey responses, “there isn’t any form of public transportation” or “public transportation is not accessible to them”. Additional barriers include the cost of transportation (37%) and weather (36%). A few respondents from the Tatamagouche area added that “if you work outside of Tatamagouche employers frown upon you for living there because of lack of reliability in the winter.”

Successes (What We Heard):

- CTCL exists and is able to provide much needed services to those who access it.
- There are various taxi services throughout the region.
- There have been some sidewalk and crosswalk improvements in specific areas within Bible Hill and Truro.

Barriers (What We Heard):

- CTCL is also hard to book, has limited resources, and the timing is very difficult. A few of respondents said they were discriminated against because of their age and ability.
- Taxi’s don’t travel to all areas (dirt roads) and very few are wheelchair accessible.
- Calming measures, lower speed limits, and the removal of some street side parking is needed on heavily traffic streets as it is unsafe to get to and from parked vehicles; for travelling vehicles to see pedestrians trying to cross, for cyclists, and for those using powered chairs or scooters who have to drive on the road because the sidewalks are not passable.
- No access between Tatamagouche and Truro for those without transportation. There needs to be a shuttle a few times a day - respondents stated “You can’t live in Tatamagouche without a car.”
- No safe bike lanes and roads are not wide enough to accommodate the one-meter rule.
- There is no consistency of sidewalk placement in the downtown areas, residential areas, or connecting downtown areas to outlying communities and vice versa.
- Stewiacke lacks designated parking areas along the street. Currently vehicles park in areas causing safety issues when traveling by car or walking along streets.
- Middle and East Stewiacke connecting roads need to be paved for better community access.
- Parking lots and spaces throughout the region are not accessible or provide safe connectivity routes to amenities. Designated accessible parking spots do not have accessibility features: spaces are not clearly marked, are not large enough to accommodate vehicles with lifts and ramps, and do not have cut-outs in curbs when roadside.
- Crosswalks do not connect essential areas to the town, for example there is no sidewalk to Stewiacke Recreation Park.

Benchmarks:

- **Ensure access to accessible, affordable public transportation.** The Truro-Colchester Region needs to provide some form of public transportation.
- **Ensure that any new development includes designated accessible parking spaces.** (see appendix for parking examples)
- **Ensure that safe travel is made a priority for the Truro-Colchester Region.** Connect the main amenities of stores, recreational facilities and outdoor spaces with well lit and clearly marked pathways to encourage the use of the spaces and promote active transportation, aligning with the Active Transportation Plan.
- **As the Taxi Authority in the Region, update the by-laws to require a minimum percentage of accessible vehicles to be licensed.** This would increase the number of accessible taxis in the area, alleviate the resource strain on the CTCL and provide more public transportation for community members until public transportation can be facilitated.
- **Implement traffic calming measures on roads without sidewalks.** Encourage drivers to find alternate routes and encourage slower, safer speeds by implementing traffic calming measures, a combination of speed humps/speed tables and also posted speed readers to remind drivers of how fast they are traveling.

Opportunities/Recommendations:

- Consult with other municipalities to build a framework for public transportation in the Truro-Colchester Region. The CBRM has Cape Breton Transit and Kings County has Kings Transit. Neither are perfect or full-serving like Metro Transit in the HRM but they both provide the bare minimum for a good portion of their population/area.

Indicators: The Municipality, Towns and Villages will monitor the following items in regard to Transportation:

- Distance covered by accessible public transportation.
- The number of accessible parking spaces at private establishments.
- Distance of connective accessible sidewalks and pathways.
- Number of accessible taxis in the Municipality.

5.6 EMPLOYMENT

Commitment:

The Truro-Colchester Region aims to lead as accessible and equitable employers, by making the Municipality, Towns and Villages accessible workplaces and supporting people with disabilities in finding and maintaining meaningful employment.

Current Offerings:

Each of the areas in the Truro-Colchester Region have dedicated teams of full-time, part-time, and seasonal employees as well as elected officials. There are many divisions and departments and many staff who are unionized and many who are not.

Overview - Community Feedback:

Overall, 57% of survey respondents from the five communities feel that there is available employment for them, personally, in their respective communities. Additionally, 69% of respondents feel that within their communities, people with disabilities are supported by employers to succeed at work. It's interesting to note that the percentage of those who feel people with disabilities are supported at work, is almost equal to the percentage of respondents who do not identify as having any disabilities.

Overview - Employee Feedback:

When asked if they feel included and represented within their communities, 89% of employee respondents said they did. 81% of employees surveyed feel that there is available employment with their employer for people with disabilities. Many shared similar sentiments as this statement "I believe our workplace aspires to be inclusive for all, though we likely have areas for improvement that require attention." 78% of respondents feel their workplaces are accessible, with 83% saying they've never experienced physical barriers at work but 60% acknowledge that there are elements of the built environments within their workplace that are not accessible.

Successes (What We Heard):

- The "Municipality recently created an Equity, Diversity and Inclusion Committee and its first focus is at the organizational level, addressing the corporate culture and workplace environment as well as the services and programs offered by the municipality. Emphasis will be directed at creating a workforce that better reflects the community that it serves while ensuring the workplace is inclusive and equitable."
- We've heard that there are a number of inclusive employers in each of the five areas within the region.
- According to employees there have been affirmative action policies put in place to ensure inclusive hiring practices.
- STEPS on Arthur provides supported employment for adults with disabilities.

Barriers (What We Heard):

- Some employees feel that there are some departments that, for whatever reason, do not appear to have much diversity. It's important to ask the question of why, i.e. type of work, internal departmental culture, lack of departmental turnover, etc., it's important to look deeper.
- Sufficient adult employment services for individuals who need to work in non-mainstream workforces are limited in the Region. (STEPS on Arthur only supports adults with certain levels of disability)
- There is not much employment for teenagers in the region, employers don't pay well but want a lot of experience. (said multiple times)
- There are limited opportunities, and the positions that do become available within the region are either entry level and minimum wage or so specific in scope that not just anyone can apply.
- Lack of transportation which limits ability to find, and maintain, employment.

- The main employer resource throughout the region are the NS Works offices and, unfortunately, they are usually ill equipped or not trained on how to be inclusive and support employers with doing so.
- The built environments of the town, village and municipality owned buildings are not accessible to everyone. “The Municipality is very transparent with their hiring practices. However, there are many physical barriers that would need to be adjusted before employing people with disabilities. I know we want to ensure we are diverse but we also need to be inclusive.”

Benchmarks:

- **Train all current employees, provide onboarding materials around inclusion and diversity for all new employees, and put policies in place to process issues and concerns should they arise.** Equity, Diversity and Inclusion training is not only an asset for organizational structures like the Truro-Colchester Region, it is required and should be included alongside other necessary operational costs. There will be an initial expense but future costs can be reduced by finding a method that works like online training modules.
- **Ensure recruitment, hiring, and career development processes are accessible to all marginalized groups.** Revisit and revise hiring policies, job descriptions, and inclusion and diversity policies within Truro-Colchester Region.
- **Update policies for managers to include the duty to provide reasonable accommodations.** Explore what accommodations would look like, and promote your policy throughout. There are likely employees who are not aware they could ask. Consider including provisions for working from home to allow for increased accommodations for staff.
- **Improve access to all built environments** to ensure employees are able to access washrooms, workspaces, common rooms etc.
- **Celebrate the diversity within your organization** and make it a priority to highlight the significance equity, diversity and inclusion plays in the Truro-Colchester Region.

Opportunities/Recommendations:

- Partner with organizations like reachAbility to create online or in-person modules for continued learning around Equity, Diversity & Inclusion for Truro-Colchester Region employees.
- Partner with agencies that represent people with disabilities and marginalized communities when hiring and commit to equity hires.
- There are financial supports through various levels of grant funding to provide the infrastructure, training and even wage subsidy not only to the Towns/Villages/Municipality but for businesses as well. **See appendix for Funding Resources.**
- Provide resources to employers/businesses in the area on how to be inclusive. Host and promote free training sessions (online or in person) and/or promote other organizations free training resources to increase awareness of accessibility and inclusion and show that the town/village/municipality sees EDI as a priority.

Indicators: The Municipality, Towns and Villages will monitor the following items in regard to Employment:

- Number of new staff trained on equity, diversity, accessibility and inclusion at point of onboarding with the Municipality, Towns and Villages.
- Number of workplace accommodations requested and approved within the Municipality, Towns and Villages.
- Percentage of Municipal, Town and Village buildings with workspaces, washrooms and common areas that meet the built environment standards.

6.0 BUILT ENVIRONMENT ACCESSIBILITY SCAN

When considering the accessibility of the built environment it is important to consider Universal Design - *“Universal Design is the design and composition of an environment so that it can be accessed, understood and used to the greatest extent possible by all people regardless of their age, size, ability or disability. An environment (or any building, product, or service in that environment) should be designed to meet the needs of all people who wish to use it.”*⁴ In order for a space to achieve universal design it needs to have:

- Equitable Use: useful and marketable to people with diverse abilities.
- Flexibility in Use: accommodates a wide range of individual preferences and abilities.
- Simple and Intuitive Use: easy to understand, regardless of the user's experience, knowledge, language skills, or current concentration level.
- Perceptible Information: communicates necessary information effectively to the user, regardless of ambient conditions or the user's sensory abilities.
- Tolerance for Error: minimizes hazards and the adverse consequences of accidental or unintended actions.
- Low Physical Effort: can be used efficiently and comfortably and with a minimum of fatigue.
- Size and Space for Approach and Use: appropriate size and space is provided for approach, reach, manipulation, and use regardless of user's body size, posture, or mobility.

Most simply put, universal design ensures that anyone and everyone can use a space in a dignified manner. It is through this lens, with the guidance of the Rick Hansen Foundation Accessibility Certification, that we have reviewed the built environment of the Truro Colchester Region.

Our Built Environment Scans took place between December 10-13, 2021, and on January 27, 2022. We have listed all of the built spaces we visited, many we were able to experience fully, some we were not able to gain full access to due to the buildings being closed at the time of our arrival and not being able to arrange an internal tour. We have included a categorized list of the spaces we visited and for each category we have provided a thorough scan of this space. Specific references and images are provided for each of the spaces, when necessary, in **Section 6.9**.

When scanning built environments, whether indoor, outdoor or a combination of built and natural space as observed in parks, there are a number of key aspects that we consider:

Buildings & Indoor Built Space

- Entrances/Exits, Passageways and Rooms: consider transitions, doors, wayfinding, welcome & inclusivity, location, safety, lighting, noise, logic, fixtures, flooring
- Furniture & Layout: consider height, depth, leg clearance, arm height, floor design, obstacles, ability, inclusivity, noise, logic, fixtures
- Stairs/Ramps: consider height, depth, transitions & colors, railing height, diameter, shape, locations and availability, wayfinding, landings, overhang, obstacles
- Elevators: consider dimensions, door width, mirrors, wayfinding and signage, sounds, buttons, button height, braille, location, availability, flooring
- Washrooms: consider availability & location, signage, wayfinding & identifying labels, stall width and turn radius, toilet (width/back), height of fixtures, sink (height/insulated pipes/clearance), amenities within reach, doors, buttons, handles and locks, coat hooks, changing tables
- Parking: consider availability & location, signage, wayfinding & identifying markings (sign on pole/painted space), curb cuts, space width and length, vicinity to other spaces
- Other considerations: additional amenities not typical of all spaces, added accessibility features like publicly accessible mobility devices (chairs, walkers, scooters), general concerns

⁴ National Disability Authority, 2020. <https://universaldesign.ie/What-is-Universal-Design/>

Parks & Playgrounds

- Entrance/Exit: consider transitions, gates, wayfinding and signage, welcome & inclusivity, location, safety
- Passage Ways: consider pathways, transitions, wayfinding, inclusivity, location, safety, material
- Rest areas: consider structure, layout, frequency and location, transitions, wayfinding, welcome & inclusivity, safety, noise, furniture/fixtures, leg clearance, wheelchair accessibility
- Equipment: consider material, durability, transitions and contrast, height, design, obstacles, ability, inclusivity, noise, logic, variety of activities
- Stairs/ladders: consider height, depth, transition textures & contrast, railing height, railing diameter & shape, railing locations and availability, wayfinding, landings, overhang/toe kick, obstacles
- Washrooms: consider availability & location, signage, wayfinding & identifying label, stall width and turn radius, toilet (width/back), height of fixtures, sink (height/insulated pipes/clearance), amenities within reach, doors, buttons, handles and locks, coat hooks, changing tables
- Parking consider availability & location, signage, wayfinding & identifying markings (sign on pole/painted space), space width and length, curb cuts, vicinity to other spaces

Trails

- Entrance/Exit: consider transitions, gates, wayfinding, welcome & inclusivity, location, safety
- Passage Ways: consider pathway, transitions, wayfinding, welcome & inclusivity, location, safety, material
- Rest areas: consider structure, layout, frequency and location, transitions, wayfinding, welcome & inclusivity, safety, noise, furniture/fixtures, leg clearance, wheelchair accessibility
- Amenities: consider water, bike support (air/repair), lighting, proximity to emergency help/telephone, durability, wayfinding, obstacles, ability, inclusivity
- Washrooms: consider availability & location, signage, wayfinding & identifying label, stall width and turn radius, toilet (width/back), height of fixtures, sink (height/insulated pipes/clearance), amenities within reach, doors, buttons, handles and locks, coat hooks, changing tables
- Parking: consider availability & location, signage, wayfinding & identifying markings (sign on pole/painted space), space width and length, curb cuts, vicinity to other spaces

6.1 Community Halls and Centres, and Recreation Centres

- Rath Eastlink Community Centre
- H. Douglas Boyce Village Hall
- Stewiacke Community Centre (Above the Fire Station)
- Scotia Pool

Featured Building: **Rath Eastlink Community Centre**

Entrances/Exits: “Main [Upper] Entrance” is locked. We assume this is because of COVID vaccine proof checking ease, however it is very inaccessible as those who park in the upper level have to travel quite a way to get to the unlocked entrance. There are no identifiable markings to know which entrance is the “main entrance” - only a sign asking you to use the other entrance when approaching the locked upper level entrance. Door opener buttons at both entrances are long vertical buttons, and are at every door. The doors are quite heavy, it is important to ensure that all doors are less than 5 lbs in weight (or less than 22N) for pull or push. It’s notable to mention that all optional/emergency exits are all by stairs and none are accessible that we were able to find.

There is clear branding on the building, making it recognizable to passersby and easy to identify for a first time visitor. The glass doors of the lower entrance have information posted on the large glass windows with wayfinding for visitors, which is helpful in providing contrast for those who are visually impaired and may not be able to recognize the glass door. There is a large hockey stick sculpture at this entrance commemorating the young who have been lost too soon, this entrance is welcoming. The lobby area is full of sports memorabilia giving a great community feel.

Passage Ways: The “welcome” desk is not obvious from the entry point. There is a slight lip when coming in the entrance which could cause an issue for people using wheelchairs and/or mobility devices independently. There are a number of tripping hazards as you enter and move toward the welcome desk - benches that are out of place or unnecessary, random garbage cans, wet floor signs and extra furniture pushed to the side, that decreases its welcoming appearance.

There were no culturally appropriate or inappropriate pieces however there were a lot of Christmas seasonal decorations which can create hazards for partially sighted and/or blind people so it is important to keep these items out of pathways. The passageways have ample built space for the public to move in both directions, however there is way too much unneeded clutter and wayfinding is inconsistent, and not appropriately placed.

The doors, handles and even the way they open, are all different. Some have knobs, some have handles. Some are automatic, some push, some pull. Some are heavy and some are appropriate weights. Directional arrows for wayfinding are needed, and more of the well contrasted signs similar to what are used on the external doors need to be everywhere. If you were a visitor to the centre, there is little support in finding where you need to go.

Fire extinguishers were properly encased and partially recessed in the walls as they should be in the main centre, however in the rink they are not. Visual and audible fire alarms were visible throughout the building. The AEDs were too high on the walls and should be lowered to no more than 1100mm in height for accessibility.

Contrast on pool windows is poor but the contrast on the fitness centre windows and automatic doors is good. All glazed surfaces must have continuous markings at both a seated and standing position so that people with low vision can identify the presence of a glass wall or door. The formalized signage that is used has ok contrast, the light green causes some issues, and the braille usage on bathroom and room identifying signs is helpful, but the location of signs and wayfinding is bizarre.

Rooms: There is no accessibility in the gym that we could find. There is very little space between machines. There are “baby parking” spaces by some machines however they do not appear to be in safe and/or large enough spaces. There are no breastfeeding friendly areas that were identified.

The Millbrook Community Rooms have moveable tables and chairs in order to adapt the room for multiple uses. They seem to be very generic rooms with little barriers that we could see. The rooms were in use so we were not able to enter them for our scan.

The rink has paper signs attached by cable ties on the railings of two sets of stairs that take you to the upper level of the rink that mention the accessible seating, but no signage anywhere besides the two stair rails. There is no indication before entering the rink that there is accessible seating or where it can be found. This is absurd considering most people who require accessible seating would not be attempting to climb these staircases. The accessible seating is clearly marked in areas around the upper and lower arena spaces, however, the accessible spaces within the “box seats” is less obvious. In order for the box seats to be accessible furniture would have to be moved which is undignified and inappropriate.

Furniture & Layout: There is ample seating throughout the space but not always in logical areas, and not always accessible. There are benches in the lobby/passageways that have appropriate leg clearance and back support and other seating (couch like seating) that does not have appropriate leg space for proper mobility support.

Most of the tables are accessible throughout and in the community rooms (legs at the corners of the table instead of pedestal style and some moveable with wheels). It is important to remember that tables/desks need to be a clearance height of 685mm minimum, with a height range of 730mm-860mm, and there should be a variety of chairs - some on wheels so they can be moved without assistance, and some that are fixed if someone with a wheelchair wishes to transfer from their chair to use the table/desk. However, the issue with the furniture in this space is less about the type of furniture and more about the clutter it causes from the extra furniture clogging up walkable/moveable space. The hallway to the changing rooms is a great example of this - there is a variety of seating, many of which are inaccessible or illogical when considering accessibility. All of which are inappropriate in a narrow hallway such as this one. Space needs to allow for 1000mm of clear width for path of travel with room for a 1700mm turn radius.

The suspension training piece of equipment that is unbarricaded but in the middle of the passageway on the upper level is dangerous. It needs to be barricaded so it is safer for partially sighted or blind persons. Additionally, the “spin centre” placed at the top of the stairs without a barricade is also unsafe for partially sighted or blind people.

Moreover, there are areas where seating should be, and it isn't. On the upper level there are no electrical outlets where the seating areas are - and no seating where the outlets are. When we visited we saw a person sitting on the floor near the outlet in order to charge their phone with a bench ten feet away. Access to electrical outlets is imperative nowadays for communication and/or accessibility needs. There should always be seating options within proximity of available outlets.

Stairs/Ramps: Both entrances (both locked and unlocked) are at ground level and do not require ramps. Additionally, there is an elevator inside so there is no ramp requirement at this location except in the pool, which we were not able to access, and in the rink. There are railings on both sides of the ramp in the rink which are appropriate size, height and shape for accessibility. The ramp should be checked for degree of elevation as it may be above the 5-6% elevation which is the acceptable standard. There is appropriate contrast at the beginning and end of the ramp and a door opener at the entrance leading directly to the ramp. It would be beneficial to have signage on the door acknowledging the accessible entrance to rinkside seating.

The stairs in the rink are adequately contrasted and have anti-slip/tactile indication on them, however it is starting to wear off. Additionally, a larger area of tactile indicator should be added to the top of all

staircases to indicate the end of the stairs and transition to the next level of flooring. There are railings on both sides of the stairs as well as directional arrows. The railings are the standard height and an appropriate shape and size for gripping to help with stability and mobility. They have a very slight lip or overhang which could be a tripping hazard and we would recommend changing them as soon as they need repair. They appear quite aged and the anti-slip/tactile indicator is almost worn down beyond recognition.

There are bright signs painted on the floors at the top level of the stadium seating indicating that none of the rink seating has railings for support while accessing the stairs. While we appreciate the appropriate signage, the lack of railings will impede movement on the stairs for those with some mobility issues like seniors or people with back injuries - railings would be ideal. Additionally, the exit stairwell that is also currently used to access the fitness center needs to have contrast and/or tactile indicator/non-slip.

Elevators: There are standard sized elevators that access all levels of the building. Button height is appropriate and accessible and railings are adequate. There are no mirrors on the back walls of the elevator to ensure that if someone is unable to turn around due to crowding they are able to see what is behind them when the door opens and closes, it is recommended that they be added.

Washrooms: The washrooms on the main level are well marked with gender and accessibility. The counters and sinks are at accessible heights, the toilets have backs on them but not all of the amenities (soap, paper towel, etc) are accessible. Some bathrooms have door opener buttons and some don't.

There are gender neutral washrooms on the main level that are labeled as "all inclusive" with paper signs fixed onto the doors. The official signage refers to them as "Family Washrooms". Family washrooms are not gender neutral washrooms. The best thing to do would be to update these single-use washrooms with labels saying "Washroom" making them truly inclusive of everyone. This bathroom did have an L shaped bar for transfer assistance which we were happy to see, but again not all amenities are at accessible heights. **See Appendix for washroom examples.** This mislabelling also happens in the fitness/pool changing room area where the room's official label in the hallway says "Family" but upon entering there is a sign taped to the wall referring to the importance of respecting "Gender variant people". We need to do better than a taped sign to the wall, and we have to use the proper terms.

Some change rooms have accessible bathrooms that are clearly labeled, some don't. There is one change room that has a lift and an adult change table, but we had to search for it. This needs to be clearly labeled so that this amenity which is rarely seen at community spaces is available to everyone who needs it. There is a key that is required for access to the lift, the key for the door should be left with the user so that they can lock their chair and their belongings in the space while they use the facilities. Additionally, as the only adult sized change table in the entire facility, this essential area should not only be available to paid users.

Parking: There were lots of wheelchair parking spots available next to both the locked and unlocked entrances. By the usable entrance the whole length of the parking lot that connected to the building was accessible parking spots as it lined the entrance to the Mental Health and Addictions - Seniors Clinic that shared part of the building. These spaces were extra wide for accessibility and had both the painted and pole identifiers for accessible parking. There was a cutout in the curb to allow for people to access the sidewalk/pathway leading to the entrance. There is ample parking on this side of the building and a safe passageway through the parking lot for pedestrians. From the crosswalk at the intersection on Abenaki Road, there is a raised pedestrian promenade with curb cuts on either end, which safely brings pedestrians all the way to another crosswalk and then to the Rath Eastlink Building.

For the upper level parking there is ample public parking and there were also a number of accessible parking spots with both identifiers. There was a curb cut out however it didn't seem adequate as it was for a crosswalk that did not lead to a pedestrian promenade or safe passageway. The crosswalk leads to an island with no curb cuts, which then leads to yet another crosswalk, again no curb cuts. There are a number of additional accessible parking spots that do not line the wall of the building, but there is no safe

passageway for any one, let alone, wheelchair users to access the building. Additionally, there aren't any spaces between the parking spots to allow for space for wheelchair users to transfer in and out of their chairs/vehicles. The passageway from this side of the building to the other side where the entrance is, is flat and mobility friendly with ample seated rest areas along the way.

Other notes: There is a wheelchair, motorized scooter and walker available on the main level for those who need to use them. Wayfinding and signage is inconsistent at best. There are great examples of black and white information signage that needs to be consistent throughout. Room labels should be larger and more eye-catching. We were unable to gain access to the pool. The fitness centre changing rooms lead to the pool and not the fitness centre, this connectivity was confusing. Does the pool have varying/adjustable depths? What accessibility features are there with the pool, the rock climbing area and the rink use? We couldn't gain access to the changing rooms for the rink either.

6.2 Municipality Building, Town & Village Halls

- Municipality of the County of Colchester Building
- Truro Town Hall
- Stewiacke Town Hall
- Village of Bible Hill Office and Chambers
- Tatamagouche Village Office

Featured Building: **Truro Town Hall**

Entrance/Exit: The main entrance has a large set of stairs and the doors do not have automatic openers. The entrance leads immediately to other doors, and is not very welcoming. There is signage on the glass windows of the doors with good contrast. The floor is low, tight carpet which is great for noise and an anti-slip surface while not creating barriers from transitioning between flooring and rugs. There is a side entrance/exit which has an “accessible entrance” with ramp and door opener and appropriate wayfinding and directional arrows to the main entrance. Carpet flooring is great for noise and anti-slip. Also a set of stairs that leads to the Town Hall drop box which is at an accessible height.

Passageways: Hallways are narrow in the public areas outside of the main office area and require the addition of directional arrows for wayfinding. If directional arrows were added for entrance/exit it would help with wayfinding and reduce crowding in hallways. Passageways need to allow for 1000mm of clear width for path of travel with room for a 1700mm turn radius. The administrative area and space between offices and the open concept workspace has a great thoroughfare room.

Fire extinguishers were a bit too high. Visual fire alarms were visible throughout the building. Fixture height may be too high, all fixtures and amenities should be at an accessible standard height of 1100mm for all standard items such as fire extinguishers, light switches, paper towel, soap, etc, with fire alarms at 1200mm. Mail holders on walls should be removed as they impede the passageway. Artwork in this space was very welcoming and diverse. Also, the adjustable lighting was great to see.

Rooms: The office spaces on level 1 & 2 were spacious and with removal of the unneeded clutter could easily be accessible spaces. The upstairs offices (IT and Tech) are not accessible. They are overcrowded with desks that are too big for the space and require more storage options. The boardrooms and community rooms had tables at accessible heights and chairs (with wheels) that could easily be eliminated to create more space. We would suggest adding a few chairs to each meeting space that do not have wheels for those with mobility issues who require a stable chair. Additionally these spaces had minimal other furniture or clutter which made them open and accessible.

We were pleased to see the accessibility updates made to the Chamber Council room - some chairs should be removed to make room for wheelchairs and/or walkers. The low carpet flooring is great for noise and anti-slip.

Furniture & Layout: As mentioned the tables and chairs in publicly used rooms (board and community rooms) meet accessibility needs but we would suggest adding a few sturdy chairs without wheels for safe transferring and/or someone who requires a sturdy chair to get in and out of. The chairs in the council chambers are all at a good height, and are sturdy and have good leg clearance for mobility assistance, some should have arms.

Office furniture is reasonable. Desks are mainly L shaped and have good leg clearance. Office chairs are on wheels which is helpful with moving around the desk area. High top desks had frosted glass panels which allows for anyone who would be using a wheelchair and/or of smaller stature to see that there is a person seated on the other side. Workspace on level 2 was very well set up in an open floor plan. Filing cabinets were placed strategically to allow for good movement and passage around the “island” of cabinets. All windows are at accessible heights.

Stairs/Ramp: As mentioned there is a ramp at the side entrance/exit. This ramp needs the addition of an anti-slip surface and better maintenance; it is likely impassable in the winter for those who need it. The railings were adequate size for gripping but too high and should be no more than 920 mm from the ramp surface to the railing and on both sides of the ramp. There were 3 entrances/exits and only one had a ramp and it was not the identifiable “main entrance”. Doorways serving as accessible routes need to have a landing at the top of the ramp that is a minimum of 1700mm by 1700mm, this should be checked in addition to the elevation (should be 5-6% maximum). There is a door opener button on both sides of the entrance for both entering and exiting through this door.

The stairs to the “main entrance” were very steep and the railings were above 920 mm. The stairs on the side by the ramp only had a railing on one side. There was no contrast on any of the exterior stairs at all, and no tactile or anti-slip/tactile indicator strips.

The stairs indoors taking you from level 1 to 3 were very old, of a ceramic tile material which would be quite slippery and with unsafe curves/spirals. The railings were well below the standard height, measuring 32” high and they were too wide, not appropriate for gripping or being used to help with stability or mobility and again, only on one side.

The stairs in the council chambers were carpeted which is good for ant-slip, however there was an overhang which is a tripping hazard. There is a ramp in council chambers in order for people to get down to the floor to address the microphone but there is only one railing on the ramp. Railings are not complete on stairs for the public, and no railing at all on the stairs for council or administrative staff areas. The contrast on the carpeted stairs did not span the complete width of the stair. The railings have no distinct end to them for partially sighted or blind people.

Elevators: Standard size elevators that access all levels of the building. Button height is appropriate and accessible, railings are adequate in the elevator. There are no mirrors on the back walls, they should be added for improved accessibility.

Washrooms: Bathrooms didn’t have L shaped or vertical bars for transfer, only horizontal. Not all amenities (soap, paper towel etc) are at accessible heights. The accessible stalls are too close to the doors. The door swing collides with the entrance to the washroom. The bathrooms can easily be made accessible by either switching the location of the stall with the non-accessible stall OR making them single use bathrooms to allow for more space and turn radius. The sinks and their proximity to the non-accessible stall is too narrow for accessibility purposes, someone using a wheelchair or mobility device would not be able to access the sink and turn around. None of the bathrooms had door opener buttons or door stops. The doors were a reasonable weight.

Parking: There was one wheelchair parking spot available next to the building, adjacent to the entrance with ramp access. The parking spot is surrounded by level ground, with no need for curb cuts, well spaced, and with a clear pathway to the ramped entrance. The parking spot has the painted accessibility identifier as well as the accessible parking sign posted appropriately on a 4 foot pole. There should be more than one accessible parking space. There are no identifiable pedestrian walk-ways from the public parking spaces at the rear of the building to the entrances.

Other notes: There is a considerable amount of clutter, everywhere but inside the office space on the main level. Great artwork throughout the building that adds a very welcoming feel for all community members and should be carried throughout. Door knobs have been replaced with door handles and it was nice to see door stops available behind most every door as there are no door openers once inside the building. There are lots of signs throughout the building however they are mostly taped to the walls and not consistently available.

6.3 Libraries

- Stewiacke Library
- Truro Library
- Tatamagouche Library

Featured Building: **Tatamagouche Library**

Entrance/Exit: There are two entrances, one roadside which has zero accessibility and we weren't able to access it during our visit, likely because of COVID, and one in the rear of the building where the parking lot is - this appears to be the main entrance. The "main" entrance has door openers, tactile indicators as you enter the building and anti-slip texturing in the entryway. The entrance leads you to a wide open space at the reception desk where you are met with a nice low level workspace with a smiling librarian. The snow clearance was pretty poor, one of the accessible parking spaces was used for a snow pile.

Passage Ways: Directional arrows support accessibility especially in areas that are not wide enough for visitor traffic to be moving in both directions. For the most part the passageways are clear with limited obstacles. There are extra power outlets in the floors which create a slight tripping hazard for someone with limited mobility but apparently there is nothing that can be done about their placement. As in most of the spaces we visited there was a Christmas tree which can cause some hazards for those without full vision, however their Christmas tree was inline with their bookshelf so the width of the shelf helps someone using a cane clear the Christmas tree without it being in their path. The only area with an obvious barrier for a passageway is the small childrens reading area that has a large table to ensure 6 ft distancing but this creates a passageway that is much too narrow for accessibility. There were great wayfinding signs supporting where to look for what type of book/reading which were large, clear font at eye level for an average height person.

Rooms: There is a second level for quiet learning that can only be accessed by stairs making it physically inaccessible to anyone with mobility barriers, however we could not go up and look around as it is closed due to COVID. There is a learning space separate from the library used as a community room which is bright and open with vision panels and good contrast. Vision panels allow for more accessibility enabling sighted people to see what is in the space even though they may not be able to physically access them. This entire space is carpeted with low carpet tile which is great for accessibility and noise reduction. The library and the learning spaces were equipped with moveable and stationary pieces making it easy to create more accessible spaces when needed. The lighting was typical for what you would expect in a space like this which was just right, not too fluorescent, but clear and helpful. There was lots of wide open space where the internet access/computer access space was as well which was nice to see. There was a space which you would enter into if using the front entrance where there were coat hooks (they were too high, some need to be lowered) with benches that provided lots of seating for changing shoes or dressing/undressing young children.

Furniture & Layout: They had a variety of chairs - some with and without arms, some lower, some higher, some for comfort and some for necessity. Some tables were permanent while others were on casters and easily moveable to increase accessibility. The book shelves were for the most part from ground to about 5 feet high. Having the shelving go all the way to the floor is very helpful for those who use a cane to assist in navigating a space and the height of the shelves allowed for open space to be achieved and increased visibility within the space. There was an accessible computer work space with an adjustable desk and seating placed throughout to provide ample rest areas.

Stairs/Ramps: There were stairs (needing railings on both sides) and a walkway leading up to the front entrance of the building. The walkway/sidewalk has severely deteriorated over time and has some large cracks/tripping hazards. There is no ramp for this entrance. The “main” entrance is ground level and does not require stairs or a ramp and has transitions between floor “coverings” that can be traveled independently by someone using a wheelchair and/or mobility device. There are stairs inside leading to the upper level “quiet study” area that only has one railing. One side of the stairs is a half wall, which is very low and quite dangerous, however the stairs are so narrow that two railings may not be feasible. These stairs do not have contrast or tactile indicators/textured covering.

Elevators: No elevator available for 2nd floor access.

Washrooms: There were two, single-use gendered washrooms. They need to have L shaped bars to support transferring to and from the toilet. We recommend removing the gendering on the washrooms as it is unnecessary and exclusionary. They are quite small without adequate turn radius between the sink and the changing table. The sink pipes need insulation. Also, it was noted that the window is extremely high and there is not a door opener button.

Parking: A paved parking lot with two “accessible” designated parking spaces. They didn’t have ample space between them and there was only one curb cut out available in the entire parking lot. One of these parking spaces was used by the plow to dump the excess snow. It is notable to mention that the library also has chargers for electric vehicles. There needs to be signage for these spaces on posts identifying these spaces for everyone, especially if the painted space is covered with snow.

Other notes: The wayfinding was very helpful. Some of it was on signs taped to the wall. It would be recommended to make all signs a consistent size and contrast (the signs on the bookshelves identifying genres are a perfect example). The staff are very friendly and knowledgeable. There is a great selection of large print books which is nice to see. It is important to note that there are three lanes of traffic in front of the library and no crosswalk to allow anyone coming from “town” to safely walk to the library.

6.4 Parks & Playgrounds

- Victoria Park
- Bible Hill Recreation Park
- Stewiacke River Park
- Stewiacke Recreation Grounds

Featured Park & Playground: **Bible Hill Recreation Park**

Entrance/Exit: The Bible Hill Recreation Park has a beautiful freshly paved parking lot which connects to the park. It is an open and inviting space. Because of the large rocks that line the parking lot creating an esthetically pleasing separation between the parking lot and the park, there isn't an obvious entrance. There is barrier-free access if parked by the changing rooms but there wasn't any clear direction to do so. An appropriate height sign is posted as you enter the parking lot with park usage guidelines for visitors.

Passage Ways: The access from the parking lot areas to the changing area/washrooms, and splash pad are all ground level. Green space is well groomed and relatively even. Most of the playground areas are not accessible as they have a wooden barrier around the various materials used as the ground. There should be areas of this barrier that are cut out and provide an accessible area for access. The passageway to access the gazebo and picnic shelters and shade umbrellas is not paved, but are well groomed low gravel pathways that most would be able to access these areas without support. Additionally there are pathways that circle the area and connect to one of the Cobequid Trails.

Rest areas: There are a number of newer metal style benches with backs on them, as well as many older style wooden benches that we have been seeing throughout the Municipality on the trail systems. It wouldn't be a bad idea to have a few more throughout the area. There are also a number of picnic tables in the picnic/gazebo area which includes wheelchair accessible tables with the extended end on them.

Equipment: There is a wide variety of equipment and play zones at the recreation park. They have recently added a new area that features wooden logs for more natural play. We would suggest including more accessible and adaptive equipment like an all ages and abilities merry-go-round, adult sized accessible swings, and more items for sensory play like noise makers, and fun things to touch.

Stairs/ladders: There are no actual stairs in this area. The play equipment has a number of stairs and ladders, there were none with ramps that we can recall. None of the equipment is overly tall so safety isn't an issue, but again we would recommend more accessible features in the play equipment.

Washrooms: There are bathrooms at this location but we were unable to access them as they were closed for the winter. There was an accessible porta-potty, but even these aren't accessible. Public washrooms are essential to have open year round, if the area stays open, so should the washrooms. There were changing rooms that were ground level and although they did not have automatic door openers they were large enough to accommodate a turn radius. There is a bench to sit on to change but is otherwise open.

Parking: As mentioned they have a brand new parking lot at this location. Accessible parking spaces need to be designated and clearly marked both with the ground being marked and posted signage. They had just paved the parking lot so none of this was done yet. **See the Appendix for Accessible Parking**

6.5 Trails

- Stewiacke River Country Trail
- John Crawford Trail

Featured Trail: **Stewiacke River Country Trail**

Entrance/Exit: The Trailhead entrance to the Stewiacke River Country Trail is located at the back of the Stewiacke Recreation Grounds. At the mouth of the trail you are met with a small wooden bridge that meets the gravel parking area, the transition is level, which is surprising given that it is open to the elements. There is a sign posted at eye level at the entrance with great contrast and wayfinding, highlighting distance, amenity placement and trail type/accessibility.

Passage Ways: The bridge at the entrance is sturdy and wide enough for accessible travel similar to a hallway. There are log pieces that stick out along the edges of the bridge to create some type of a barrier. Although aesthetically it wouldn't be as pleasing, we would recommend either a proper 920 mm high railing or atleast a solid rail along each side to be cane detectable. The trails are well groomed, quite level and with little elevation. The trail is 2.5 km in length, links the Stewiacke River Park and Mastadon Ridge and then loops around the park again. At a few points there are areas where you can go off the trail to get closer to the river, we would suggest adding some type of railing to these spots to ensure safety for travelers as this area along the river isn't as well maintained.

Rest areas: There are a number of rest areas along the trail which are wooden benches with backs on them. We would recommend cutting out the wooden piece that closes in the foot area of the bench. It would not affect the stability of the bench but would provide more mobility support for those needing to get their feet under them to get up, especially where the benches do not have arms on them. There should be a resting area every 30 feet along the trail.

Amenities: As mentioned, this trail isn't extremely long so it can be expected there are limited amenities. There could be some more garbage receptacles, we suggest having one with every rest area and perhaps provide more signage along the trail to let people know where they are and how far they are from their destination. (This may be in place, we did not complete the whole trail due to weather conditions, but if it is not in place, it should be)

Washrooms: There are no washroom facilities on the trail. There are washroom facilities at both the Stewiacke River Recreation Grounds and also Mastodon Ridge but, neither were open during the winter months. Public, accessible washroom facilities are important missing pieces to the great outdoor spaces in the region.

Parking: There were no designated parking areas at the Stewiacke Recreation Grounds, accessible or otherwise, but there are when accessing the trail through the Mastodon Ridge trailhead. There are accessible spaces clearly marked at Mastodon Ridge, however there is not a clear and safe passageway from the parking spots to the trail.

6.6 Fire Halls & Police Stations

- Bible Hill Fire Hall
- Stewiacke Fire Hall
- Truro Police Station

Featured: **Truro Police Station**

Entrances/Exits: The entrance of the building is accessible both by ramp and stairs. There are door openers on both sets of doors as you have to go through two sets to get into the police station. The reception area of the police station is very welcoming, there are lots of signs that include Mi'Kmaq information, wellness information, and lots of community resources.

Passageways and Rooms: We weren't able to get access beyond the lobby.

Stairs/Ramps: The stairs are very steep and do not have enough rails. The staircase itself is wide enough to require a set of railings in the middle of the staircase to allow for someone to be able to have railing access on both sides of them as they walk up and down. The ramp is sufficient and includes small solar lights to keep the area well lit in the dark.

Elevators: We did not get to see the elevator but we were told there is one.

Washrooms: There is an accessible, gender inclusive, single use washroom equipped with handles and easily accessible locks, coat hooks, and even a changing table.

Parking: We did not see a designated parking area for the police station however there are a number of parking lots around this area for the farmer's market, library etc.

6.7 Sidewalks, Storefronts, Signs, Public Offices

- Sidewalks
- Storefronts & Public Works Offices
- Town/Municipality/Village Signs

Feature: **Town of Stewiacke Maps and Signs**

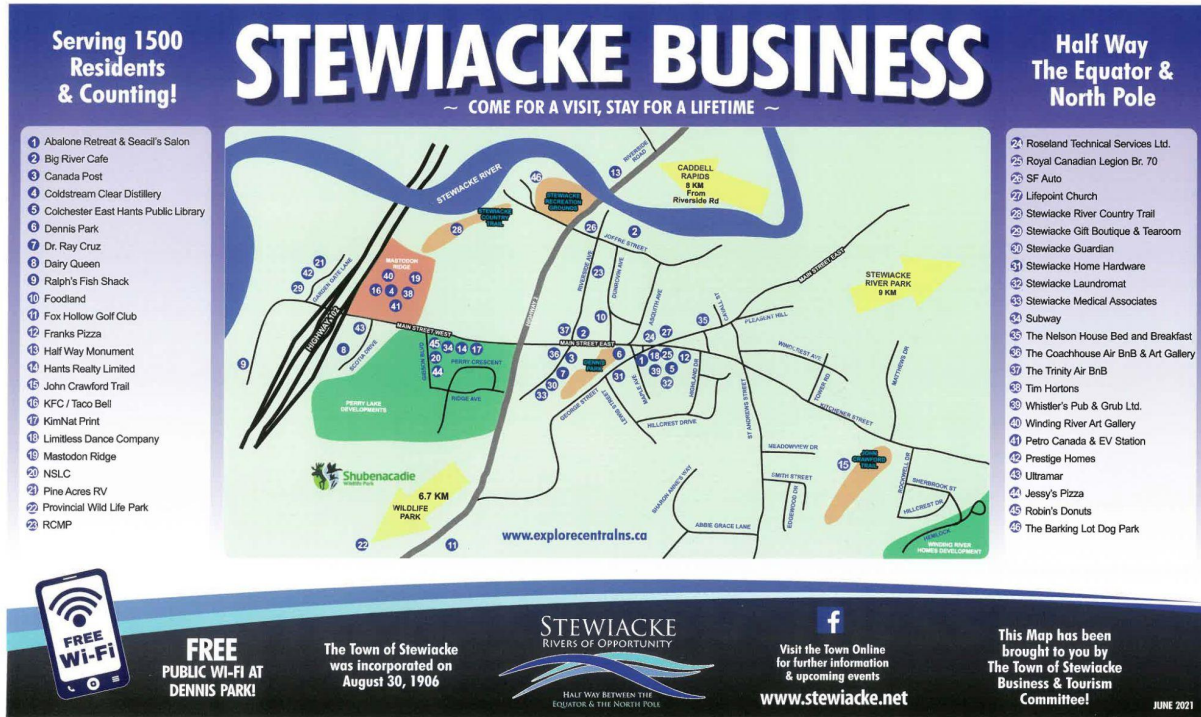

The above sign is a low resolution image of the Stewiacke Town Map. Various versions of these maps are located throughout the town giving reference to where you are, and providing information on destinations you may be hoping to travel to. Important features of these maps:

Contrast: Color contrast is essential for individuals with low vision to be able to read and understand the information provided. While the shades of blue in this map could have a bit more contrast, this is a great example of how you can stay on brand and create accessible documents. The use of colors that would be easily recognized and understood (green for grassy areas, blue for water), contrasting colors are also used for directional arrows, streets and more.

Font size and style: While it is recommended to use Tahoma, Calibri, Helvetica, Arial, Verdana, and Times New Roman. Slab serif fonts are also considered to be accessible. A size 20 font is generally suitable for folks with low vision.

Essential information: Without crowding the space it is important to make sure that signs have a function. This sign not only provides directional information for amenities, businesses and essential services, it also provides essential contact information, and identifies where free wi-fi access is in the area - all while remaining accessible and on brand!

6.8 Tourist Attractions & High Traffic Areas

- Tatamagouche Creamery, Farmers Market, Arts Centre
- Masstown Market and Creamery
- Stewiackes' Welcome and Information Centre at Mastodon Ridge

Featured Tourist Attraction: **Tatamagouche Farmers Market**

Entrance/Exit: The main entrance has a small lip that would likely require assistance and/or being quite physically strong for someone with a mobility issue. The door was standard width. There were no ramps or door opener buttons, however they had the entrance/exit propped open which we would assume could be done depending on the weather. Entrance leads directly into the market space, the busy nature of the farmer's market is very welcoming however there is no signage or wayfinding, you just have to go with the flow of traffic. The flooring was vinyl tile, with a small short carpet rug for drying ones feet on before proceeding through which is great for reducing the opportunity for slipping. The aisles of the space were wide enough to provide the 1000mm clearance but with heavy foot traffic that would be hard to achieve without barriers.

The side entrance that leads out to the patio area also did not have a ramp or door opener button but it was propped open the same as the main door. The door was standard width. There was a larger lip to get out this door which again would require some support. There wasn't any wayfinding, we just followed the flow of traffic out the door. We are assuming the other was the entrance as it was in the closest proximity to the parking spaces and had a larger "Tatamagouche Farmers Market" sign across that whole side of the building. This door took you out on to a wooden platform for a few other vendors, the wood was a bit wet from weather, which could cause some slipping hazards.

Passage Ways: The market was one open space (except for the washrooms). The space was well set up with a nice wide passageway circling the room of vendors. There wasn't any clutter in the footpath that could be a barrier or hazard. There wasn't any helpful wayfinding except the signs identifying the bathrooms. The flooring was vinyl tile which was consistent throughout the space which as mentioned could become slippery, but didn't cause any barriers with flooring transitions. There was one of the standard yellow wet floor signs by both doors, these could cause hazards for partially sighted or blind people. Something with a solid bottom would be better than these signs as they wouldn't easily tip over or get caught in a cane if being used for navigation.

Fire extinguishers and/or fire alarms were not visible throughout the building. Fixture height may be too high, maximum height for fixtures is 1100 mm and fire alarms are 1200mm.

Rooms: Other than the main market the only two spaces to comment on were the makeshift kitchen being used as a permanent vendor space where you can get snacks, lunch and hot drinks and the outdoor space. The kitchen had accessible height counters, however there wasn't a great turn radius in the work space and there were plenty of barriers from clutter, trays of food being sat on top of things in order to make room etc. We didn't get to look too far in, but from what we could see, it wouldn't be fully accessible.

The outdoor space consisted of a small platform selling/vendor space and a step down open green space area surrounded by a railing to create a closed space. The selling/vendor space had uneven ground which could cause barriers and there was no defined edge to the platform. There was a natural level change to get to the lower area and/or a small step of 3-4 stairs. The stairs didn't have contrast or proper railings, the ramp or level change was not well maintained in the snow. There were a few picnic tables that were not accessible. The railing provided an appropriate barricade from the river below, to the right of the railing was a wooden ramp to go closer down to the river which had a railing on the left side. It was incomplete and not on both sides and the ramp which was slippery as it was all wood. There were not appropriate barricades to safely keep the visitor from mistakenly getting too close to the water. This space needs to be

re-imagined and updated for safety and accessibility. There was no signage or wayfinding explaining what this space was, what was there or how you could move around.

Furniture & Layout: The aisles were clear of clutter and there was a very obvious directional flow around the market although there was no wayfinding or signage. The market tables all had good clearance and where the legs did not span the width and length of the table, the tables had floor length tablecloths on them which would help identify the table for anyone using a cane to assist with getting around. Displays were all at accessible heights. There were some table top displays that would be a bit high but there was always a variety that was accessible to everyone.

Picnic tables that were outside were not accessible to everyone. Tables and chairs for seating inside had pedestals on them which would allow for leg clearance however without the chairs around them, they would become hazards for a partially sighted or blind person. This did not stick out to us upon further review as a barrier as the seating area was separated from the “flow” of traffic and wouldn’t typically be in the way. Also good to note that although there was a Christmas tree there, it was tucked in behind other things and didn’t create a barrier.

Stairs/Ramps: Ramp only outside leading to the river. Has one railing, needs another and needs anti-slip tread. Incline could be checked, but if well maintained for all weather and/or closed when it can’t be it should be accessible. Barriers needed to better obstruct the river so that no one gets hurt. The view of the water is a great option for visitors. Stairs outside don’t have appropriate contrast or railings. No stairs inside. Transition color or texture needs to be everywhere there are floor transitions.

Elevators: No need for an elevator as it is solely one level.

Washrooms: There is an actual changing table in the way when entering which makes the space too narrow for wheelchair users. The entrance has lightweight doors which is helpful as there is no door opener button. The sliding latch on the doors is great for limited dexterity. The “accessible” stall doesn’t seem to have the needed clearance for turning or transfer space. There needs to be an L shaped bar for proper transfer support. The sink has proper leg clearance if the “diaper” garbage can was removed and the pipes were safely insulated. Fixtures and amenities in the washroom are a bit too high.

Parking: As the area where the Farmers Market is located houses many attractions it appeared to be like parking was just “park anywhere that is safe and available”. There were some designated spaces that lined each of the 4 buildings and an extra lot above the tracks from where the buildings were located. There only seemed to be one “accessible” parking spot that we could see which had a pole posted with the accessible parking designation. This space was in front of the museum and not really close or easily accessible from the Farmers Market - but we understand that may not be possible given the way the “Creamery” space is laid out. We would recommend having at least one space per building/attractions. The space did not seem large enough, however it was a gravel parking lot so it would be hard to define the space.

Other notes: Wayfinding could be improved from the road down into the “Creamery” and throughout the outdoor space. Everything has an identifying sign but there is no explanation as to what or where things are, why you should move from one attraction to another, what each space was used for etc. For example there was a stage there, and no explanation as to what it was used for, what organization it belonged to etc. There was a “General Convenience Store” again, not noted by any wayfinding signage or explanation, but we couldn’t get it. It was a very small space, not accessible at all and was crowded when we attempted to. Snow clearing was an issue at this location overall, on pathways, parking spaces, thoroughfare areas etc.

6.9 Specific Built Environment Barriers

There are a number of accommodations and/or adaptations that can be made to the built environments throughout the Truro-Colchester Region. We have provided some specific examples below:



Community Halls and Recreation Centres Rath Eastlink Community Centre

- This is the accessible seating area in the Rath Eastlink Centre Arena. This space is not accessible; it would need to have a turn radius of 1500 mm in order to accommodate a wheelchair. This person is 5'2" tall and can barely sit in this space.
- Behind the seated person you can see the ramp and railing. The railing should either extend out 300 mm beyond the end of the ramp or distinctly turn down to show it has ended.
- There also needs to be tactile indication at the landing space at the top of a ramp to indicate to someone who is blind or has low vision that the ramp has ended and they have reached the next level.



This is the upper level parking lot. All of these parking spaces along the building are designated accessible parking spots.

- There is only one curb cut out to access the building entrance from these parking spots and it is to the far right of these spaces. One curb cut out is not adequate for these spaces. There should be space between the parking spots and lining up with those spaces should be a curb cut out for safe access to the pedestrian walkway.
- There isn't a safe way for someone to get from these parking spaces without having to travel behind parked vehicles.
- Additionally, there aren't any spaces between the parking spots to allow for space for wheelchair users to transfer in and out of their chairs/vehicles.



Community Halls and Recreation Centres H. Douglas Boyce Village Hall

The Village of Bible Hill has made a number of accessibility updates to their Village Hall. One of the spaces they haven't updated yet, is their registered kitchen.

- In this photo you see a fire extinguisher in an inaccessible location. Fire extinguishers should be no higher than 1100 mm from the ground and should be encased and/or recessed into the wall.
- Also in the photo are a number of regularly used items all of which are inaccessible. Soap and paper towel dispensers and first aid kits (which you can partially see the label on the cabinet overhead) are all amenities and/fixtures which should be no higher than 1100 mm from the floor and have barrier-free access.



- The moveable trolleys seen in this photo are great assets in this kitchen both because of their height and the fact that they move easily with their casters. They should be stored somewhere else in order to keep a wide enough passageway.
- The counters and cabinets in this kitchen are too high which makes anything on the counters inaccessible to anyone in a wheelchair or of smaller stature.
- The layout of the kitchen with the stove, two fridges and microwave all in one area of the kitchen makes the usability of this space difficult while trying to keep an area appropriate for adequate turn radius.



Community Halls and Recreation Centres Scotia Pool

- No ramp or lift for pool entry
- No wheelchair accessible changing room or washroom
- Automatic door opener for entrance not in an obvious place, and the button for exit placed above a radiator

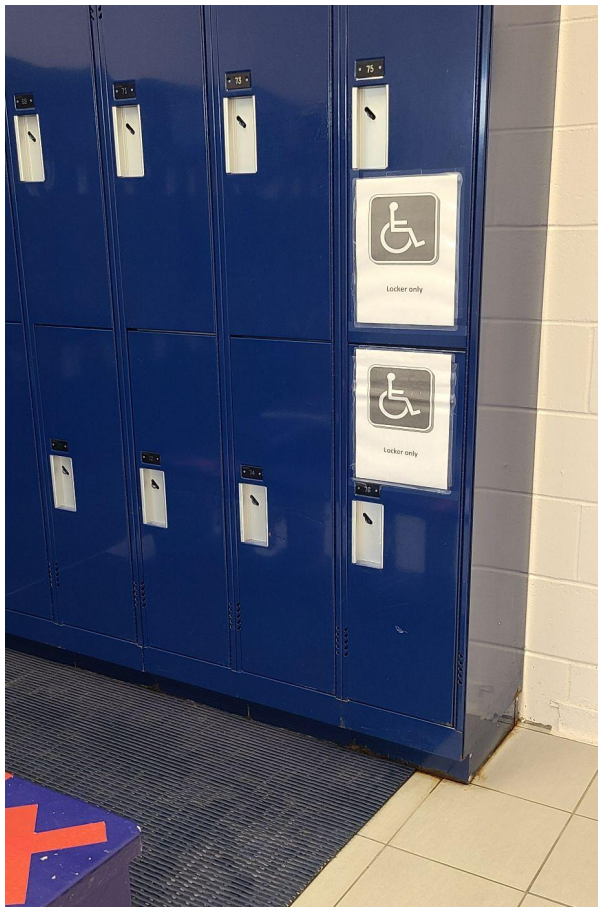

- Locker room has designated accessible lockers but there isn't a large enough space for turn radius
- Concrete pathway from the parking lot to the entrance is not well maintained, quite weathered and uneven.
- Building not welcoming from the outside, no directions or signage other than the name on the building to even make someone think they have arrived at the community pool.



Community Halls and Recreation Centres

Stewiacke Community Centre

The Stewiacke Community Centre is above and behind the Stewiacke Fire Department and next to a child care centre. We were unable to access the centre.

- Entrance is not very inviting. Very little signage other than paper signs taped to the doors and a large no parking sign above the entrance.
- Doors do not have an automatic opener and the handles require a lot of dexterity to push the latch down with your thumb at the same time as you pull the door open.
- The deck is large enough to accommodate a turn radius, and the railings are appropriate heights; however as the picture depicts, the deck gets quite wet and also slippery with the weather. This should have tactile indication/anti-slip surface at least for the pathway from the stairs and ramp.



- The parking lot holds a lot of water and can become quite uneven from the weather making mobility difficult.
- There is one designated accessible parking spot, the sign is posted on the side of the ramp, but because of the gravel parking lot and the clutter of additional railings, propane tanks and garbage bins, the accessible spot doesn't stand out.
- The ramp is an appropriate elevation and has tactile indication/anti-slip on it, but the railings are not round and graspable, which is ideal, especially where this ramp will see a lot of weather. An additional handrail should be added for accessibility.



Municipality Building, Town & Village Halls
Municipality of the County of Colchester Building

This is one of many staircases in the building.

- Railings are required to be on both sides of a set of stairs.
- The railing is too low, and too wide for safe passage. Railings should be at least 860 mm and be a small enough diameter that it is easily graspable.
- Stairs require contrast on them. The riser should be an opaque color and the tread should be a bright or dark contrast color.
- Stair treads should have tactile indication on each stair and at the top of the staircase.
- There is an overhang on these stairs which causes a tripping hazard



This is the lobby that greets you when you enter through the main entrance of the Municipality of Colchester building.

- The entrance has a steep set of stairs and no automatic door openers.
- There is a floor plan for the building on this level but it does not have good contrast and would be difficult for someone with low vision to read.
- This counter, for which citizens have to use to pay tax bills, is too high for accessible access and there is not an alternate window or counter to use for this service.
- The barriers used to create a line up are not in an obvious place and could interrupt the pathway of someone who is blind or has low vision. A more solid barrier would be preferable.



Municipality Building, Town & Village Halls Truro Town Hall

These are the council chambers on the third floor of the Truro Town Hall. There have been many accessibility updates to this space which include a ramp for public access to seating and to the lower level in order to access the microphone. However:

- There are stairs for Council Members to use to get to their seats.
- The stairs do not have appropriate contrast or tactile indication.
- The stairs are too close to the chairs, especially chairs on casters.
- There is no accessible access for any member of council which means if someone in a wheelchair were to be on council they would not be able to sit in their earned seat.



This shows the public seating area of the Town of Truro's Council Chambers.

- Some chairs should be removed in order to have space for someone in a wheelchair to attend.
- The ramp which faces forward on the right hand side of this photo does not have rails on either side of the ramp in order to allow for folks to access the seating, but this leaves a part of the ramp that extends past the seating without a railing.
- Some of the chairs should have arms on them to provide more support for community members who may require them for balance while sitting and also to assist with standing back up.



Municipality Building, Town & Village Halls Stewiacke Town Hall

This is a space in Stewiacke's Town Hall. We know that the Town Hall is moving to the Public Works building but we want to highlight some issues in their current space.

- There is a step up into the space and now ramp or elevation to assist with it.
- There is no bright contrast showing an obvious step, in either direction, and no tactile indication when you step up and enter the space.
- The chair immediately in the pathway upon entering the space is creating a narrow pathway and a tripping hazard.
- The paper towel dispenser and the shelf with storage are much too high for accessibility.



This is the lobby/entrance of the Stewiacke Town Hall. It is an open space but not a very welcoming one.

- The entrance is slightly above ground level but they have smoothed out the elevation with a concrete man-made ramp.
- There is an automatic door opener but we would expect this entrance is hard to navigate independently.
- There is no signage or anything indicating what you should do upon arrival.
- The counter/window is too high.



Municipality Building, Town & Village Halls
 Village of Bible Hill Office and Chambers

This is the Village of Bible Hill Chambers.

- The furniture in this space is all moveable, but in its current layout the passageways to get around to each seat are too narrow to also allow for a turn radius if someone were to leave the table.
- This space is very colonial. All of the artwork is of the queen and/or very colonial referenced pieces.
- There should be some variety in the chairs for those who need more stability than what a chair on casters can offer.
- The fluorescent lighting is not recommended.



This is the part of the Village of Bible Hill's Office lobby. The entrance is ground level and has an automatic door opener.

- The Christmas tree added to the welcomeness of the rather plain entry way, however Christmas trees are one of the most common "seasonal" barriers for people who are blind or who have low vision because they do not continue all the way to the ground and therefore are not cane detectable.
- This space could use some signage or wayfinding. There is a bathroom also available in this space but nothing really stands out except a number of closed doors, which is a common theme in most of the town halls/village offices we have visited in the region.



Libraries

Stewiacke Library

The Stewiacke Library will also be getting a new home soon, but we wanted to point out a few issues. It is notable to mention that the measures the folks at this library have taken to make this very inaccessible space and make it accessible is admirable.

- Railings are needed on both sides of ramps and stairs, no matter the size of the ramp or the number of stairs.
- Narrow passageways should not be cluttered with extra things like tables, plants, recycling bins etc.
- Book shelves should not be any higher than 1200 mm (1100 mm is ideal)



- Fire extinguishers should be recessed into the wall or encased and out of the way
- AED machines and necessities like first aid kits, fire alarms, light switches and other fixtures should be no higher than 1100 mm.
- The filing cabinet/printer set up is creating a barrier for accessing the doorway.

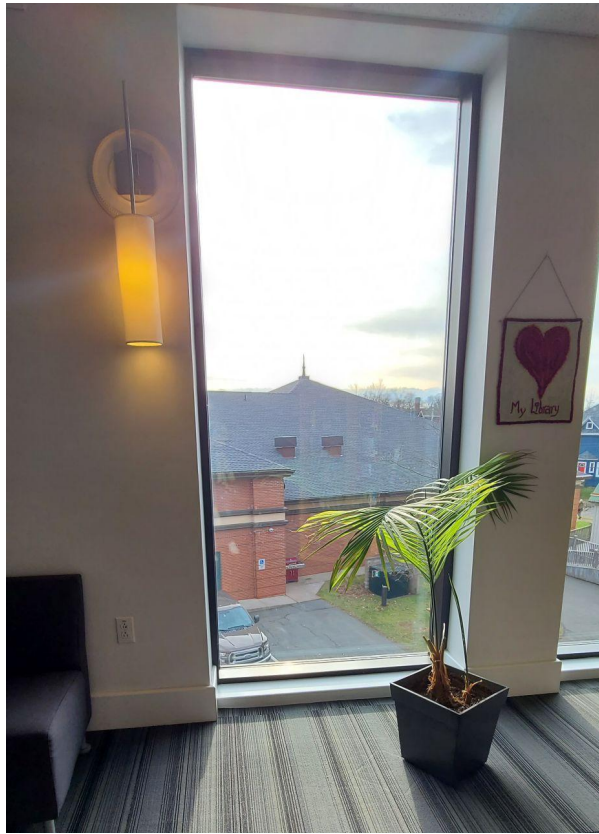

Libraries

Truro Library

The Truro Library has been renovated to be a very inclusive and accessible community space for the Town of Truro and surrounding areas.

We love the variety of seating, the low carpet tile and the wide open spaces. However:

- These full length windows need to have continuous contrast on them in order for people with low vision to recognize that it is a glass window.
- The plant is dangerously placed and could be a tripping hazard.

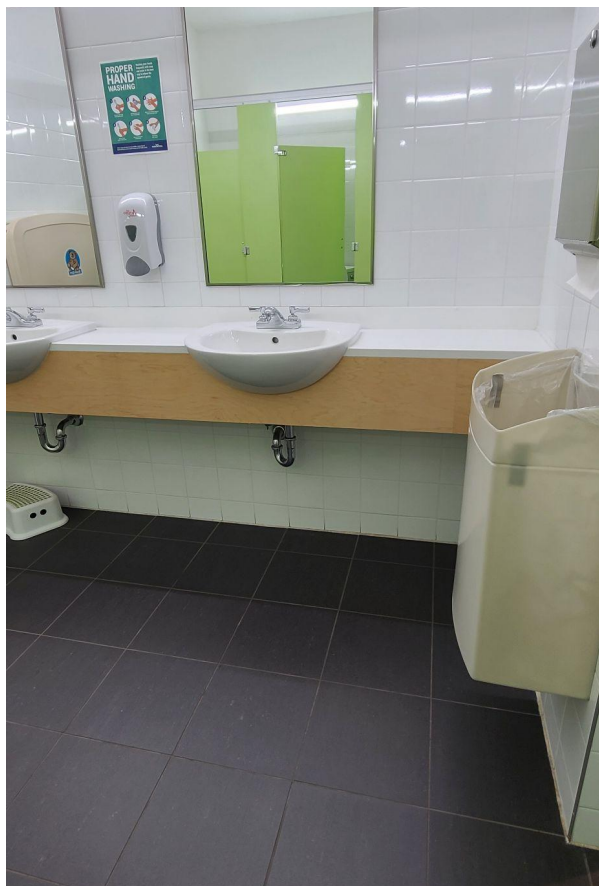

This is one of the bathrooms on the main level of the Town of Truro Library.

- The sink pipes need to be insulated to avoid harming someone's legs
- The garbage can directly below the paper towel dispenser creates a barrier for accessing the paper towel dispenser.
- The wheelchair accessible stall does not quite have the proper transfer space and turn radius.
- It would be nice to see in such a well used public space like this that has had such accessibility upgrades, a single use washroom equipped with an adult size change table.



Libraries

Tatamagouche Library

- This appears to be the main entrance of the library but this entrance is not being used, and there are no signs asking you to use the entrance at the rear.
- There is no sidewalk access to the Tatamagouche library and it is next door to a school.
- There is no crosswalk that allows a pedestrian to get from “downtown Tatamagouche” to the library safely.
- This entrance has stairs and a paved walkway that is quite aged and cracked.
- This entrance also does not have a ramp or automatic door openers.



- One of the spaces is inaccessible due to the snow plow leaving the snow on top of the space.
- There are not posted signs marking these spaces should they be covered in snow.
- There is one curb cut out for access to the library for the entire parking lot which leads us to believe that the white lines are to be a crosswalk per say and not the additional spacing for the accessible parking spots.



Parks & Playgrounds

Victoria Park

Victoria Park in the Winter

- Trails are not well maintained for walking.
- Rest areas not cleared of snow.
- Signs throughout the trails are very small. They have lots of color contrast but are small and hard to read for most.
- Should be more information about what is safe to use and what is not. If this information is available somewhere, it is not obviously available to everyone as we couldn't find it.



- This is the only sign at the entrance of the park. This is well before the bathrooms and the end of the parking lot.
- Beyond this point there is little direction as to where things are, especially for the non-trail aspects of the park.
- Map is worn and not well contrasted anymore, could be replaced. Additionally, the green's used in the Victoria Park signs do not provide any contrast. Wayfinding is very important especially for such a multi-use, popular space like Victoria Park.



Parks & Playgrounds

Bible Hill Recreation Park

- No designated parking spaces at all, let alone accessible parking. (This is a brand new parking lot and it just wasn't done yet)
- The separation created by the large boulders between the parking lot and the park space don't only create a barrier for vehicles but for people as well. There is no logical entrance to the park.
- There needs to be more signage and wayfinding directing people to the different amenities of the space.
- Remove the red bench and allow for a barrier free entrance to the splash park for everyone.



This is the washroom and changing room building located at the Bible Hill Recreation Park but there are no signs to tell visitors that.

- This space is level with a beautiful new concrete slab that meets the newly paved parking lot. The other side of this building where the bathroom and changing room entrances are, could be a great place for a lot of accessible parking with barrier free access to the park and all of its amenities, but currently there are zero signs.
- Bathrooms were locked and not available for use during the winter.



Parks & Playgrounds
Stewiacke River Park

Picnic rest area is placed on a hill much too close to the river and uneven ground.

The only accessible picnic tables are further into the park in the picnic gazebo.



- There is very minimal signage and/or wayfinding at the Stewiacke River Park.
- This is an example of an inaccessible sign.
- The best signs were in the accessible bathrooms.



Parks & Playgrounds
Stewiacke Recreation Grounds

- This park has very few options for play space, none of which are accessible.
- There needs to be better drainage for better access to the playground from the driveway/roadway



- This building is in very poor condition. There are parts of the awning that are falling down.
- There is a play box of sorts here for equipment use but it was locked and not in service.
- There were no usable washrooms at this park.



Trails

Stewiacke River Country Trail

- The bridge to the Stewiacke River Country Trail needs a cane detectable railing.
- There is no designated parking, accessible or otherwise at this entrance.
- There are some river access points along this trail that need some attention.



Trails

John Crawford Trail

- This is one of the more poorly maintained trails in the area. There were lots of fallen branches and debris.
- There are various elevations along this trail that could use some railings for support that are graspable. The railing in this photo is less usable for support and more for directional purposes.
- This trail could be more accessible if the trail was widened some, which seems doable, at least for the length of trail we covered.
- The descriptions of the trails could be a little more thorough beyond length and trail material so that travelers are a bit more prepared for what they will encounter.



Fire Halls & Police Stations

Bible Hill Fire Hall

There have been a number of upgrades made to the Bible Hill Fire Brigade's Fire Hall including a lift.

- These stairs need contrast and tactile indication;
- Continuous railing from beginning to end, and also extended railings past both ends or a rounded end to let the user know that the stairs have ended; and
- A tactile indicator strip at both the top and the bottom.
- Additionally, there is a lip or overhang on these stairs which can create a tripping hazard.



This is the kitchen in the upper level of the Bible Hill Fire Brigade's Hall.

- The space has adequate turn radius and is rather barrier-free,
- The microwave, paper towel dispensers, above the counter electrical outlets are all at inaccessible heights.
- The shelving above the fridge, and items stored on top of the fridge are also too high.

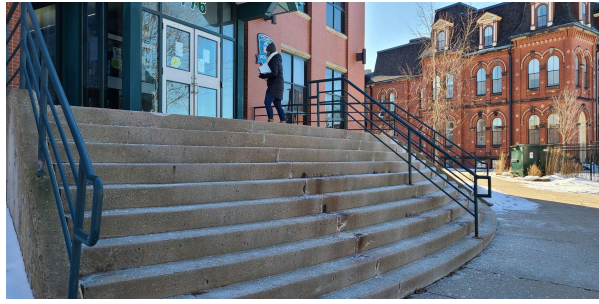

Fire Halls & Police Stations

Truro Police Station

- More railings are needed for the width of this staircase.
- There is no contrast or tactile indication on treads, or at the top or bottom of the stairs.

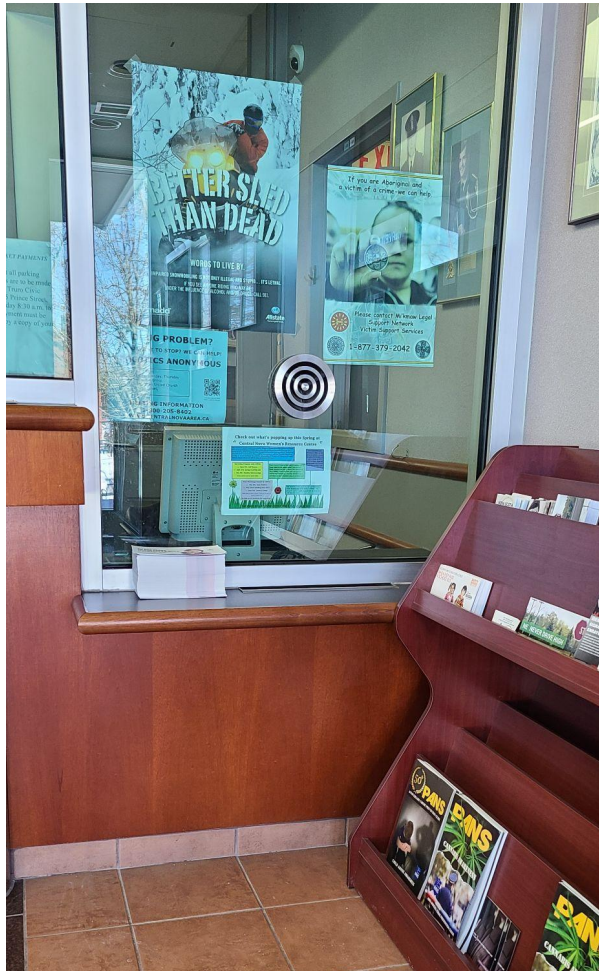

This is the reception area of the Truro Police Station.

- It is great to see so much information provided for the community, and although it does provide contrast on the glass, it should not be all over the glass where people are supposed to be speaking to staff members.
- There is another space to speak to staff through the higher counter, but this is the accessible counter and it is physically barred by the shelf full of brochures and additionally barred by the posters.



Sidewalks, Storefronts, Signs, Public Offices

Sidewalks

Tatamagouche

This is the main sidewalk in Tatamagouche which serves the entire main road from the entrance of the Village all the way down to the Library, Fire Hall and School.

- Sidewalk condition is poor, cracked and uneven pooling water from the weather.
- Roadside parking and getting from parking to the sidewalk is barred because of snow removal issues.
- Pathways from sidewalk to businesses were not cleared or accessible.



Stewiacke

These are the sidewalks in Stewiacke near the Town Hall, Library and Public Works Building.

- Sidewalks are in poor condition
- Snow removal is less than adequate.
- There is no curb or shoulder to the road that is defined.
- You can see that vehicles park and/or drive on the sidewalk when necessary.



Sidewalks, Storefronts, Signs, Public Offices Town/Municipality/Village Signs

This sign was found on the side of the Farmer’s Market Building in Truro. It provides wayfinding and reminds the reader about a few “house rules” for the area.

- There is a lot of text to read, and the font is too small.
- The colors do not provide enough contrast for people with low vision.
- There is no contact information provided in case someone has questions or concerns.



These signs were found in the Municipality of Colchester Building.

- All the signs are different colors with different fonts and font size.
- All the signs at different, and inaccessible heights and in varied directions.
- None of the signs provide directions.
- Furthermore, there is a large piece of storage furniture in the doorway creating an inaccessible doorway.



Tourist Attractions & High Traffic Areas

Tatamagouche Creamery, Farmers Market, Arts Centre

- There is a lip at both entrances of the Farmer's Market building and no ramp, contrast or signage.
- Passageways from parking to the building are non-existent.



This is a ramp to the river behind the Farmer's Market Building in the Creamery.

- There are no signs explaining where this ramp goes.
- There is only one railing, and there should be one on both sides.
- The ramp was not closed, and did not have snow removed, neither did the deck that it extends off of.
- There is a barrier at the end of the ramp stopping you from entering the river but it does not provide a safe enough barrier as you can see at the end of the ramp in this photo.



Tourist Attractions & High Traffic Areas Masstown Market and Creamery

This is an entrance and exit at the Masstown Market.

- There are no directional arrows showing you where to go, here or anywhere in the Market.
- There are no automatic door openers.
- The fire extinguishers are not recessed into the wall or encased.
- The checkout counter and debit machine are quite high.



This is a seating area at the Masstown Market.

- There are accessible seating areas with tables at appropriate heights and chairs that are light enough that they could easily be moved to the next table.
- There is an electrical outlet here, which is convenient for the folks seated here, but their seats and tables are bar height and not accessible. There are more outlets available, but again none at accessible spaces.



Tourist Attractions & High Traffic Areas
Stewiacke's Welcome and Information Centre at Mastodon Ridge

The Mastodon Ridge area is privately owned but because the Stewiacke Information Centre is located here we felt it important to visit.

- There are too many sets of stairs here, made of all different materials and types of stone.
- The only ramp is the one here in this picture which is created by recessed brick. It gets damaged by the weather. You can see that the entry to the ramp is receding, we had to replace two of the bricks in that area before taking the photo.



This is the accessible parking area for both the Stewiacke Information Centre and the Stewiacke River Country Trail access point, at Mastodon Ridge.

There is no safe passageway for pedestrians from the accessible parking spot to the Information Centre or the trail head.

7.0 TIMELINE VS PRIORITY PHASING

Given that we know there are many different strategic plans guiding changes that are underway throughout the Truro-Colchester Region we have opted to provide timelines for these recommendations rather than prioritizing them. As we have noted many times throughout this report, and as the Truro-Colchester community is fully aware - immediate action needs to be taken to alleviate the barriers created by much of the built environment at Truro-Colchester Region. We have not addressed these overarching issues in our recommendations but identified how programs, services and physical space can be adapted to alleviate these barriers in the meantime. Below are reasonable recommendations within suggested time frames that we feel can significantly improve upon the accessibility of the environment of Truro-Colchester Region while building a sense of trust and community. When addressing these recommendations keep in mind these five steps for implementation as identified in Access By Design 2030.

- 1) **Developing the Standards:** using recommended benchmarks, develop standards as to how implementation within the Truro-Colchester Region structure will occur.
- 2) **Build Capacity and Awareness:** All Truro-Colchester Region staff build capacity through training. Truro-Colchester Region promotes inclusive priorities with an awareness campaign.
- 3) **Collaborate and Support:** in collaboration with marginalized groups and agencies build relationships of mutual respect and support.
- 4) **Compliance and Enforcement:** based on the developed standards and using the recommended benchmarks the Truro-Colchester Region implements these standards and clearly identifies compliance and enforcement strategies.
- 5) **Monitor and Evaluate:** as with any growth and change it is essential to revisit, reassess and revise policy and implementation.

7.1 Immediate (within the next two years) - *These recommendations are immediate as they include policy and attitudinal barriers, which require less structural change to the environment at Truro-Colchester Region as well as Built Environment recommendations focused on making minor adjustments to current structures that will increase accessibility, all of which are eligible for provincial funding.*

- Determine core Diversity, Equity and Inclusion competencies for each level of staff and create an implementation plan for training. Train current employees, and include this essential learning as part of your onboarding process for all new staff. Revisit the Human Library approach that Truro has previously taken and consider revamping.
- Revisit and revise hiring, accommodation and Diversity, Equity, and Inclusion policies and ensure they are inclusive.
- Appoint a Director of Compliance or designate the role to an existing position to focus on accessibility compliance.
- Revisit by-laws and include the requirement for designated accessible parking spaces for all new developments.
- Determine a strategy for increasing access to public transportation for the region.
- As the Taxi Authority in the region, update the by-laws to require a minimum percentage of fleet to be accessible vehicles in order to renew licenses.
- Review brand guidelines and update ensuring accessible font, font size, and contrast are included.
- Create an Accessible Signage Standard.
- Create an accessibility awareness campaign, and ensure that accessibility is seen as a priority.
- Re-evaluate the various systems and platforms that are being used for services and communication and ensure they work efficiently with assistive technology.
- Create an Accessible Communication Standard. Ensure all communication is delivered in accessible formats (including ASL interpretation and captioned video content) and can support the use of assistive technology.
- Create a regional standard and implementation plan for crosswalks and sidewalk installation and

maintenance ensuring accessible, safe, connectivity between amenities and areas of the community. The standard should define minimal requirements for varying levels of usage for example: downtown core, connective routes from downtown outward, and residential areas significantly outside of the downtown core.

- Consider offering “Play Boxes” at various park locations that provide easily accessed, free, adaptive play items to promote unstructured recreation activity.
- Extend the hours for public services like libraries, solid waste, recycling, bill payments etc.
- Creating opportunities for community building by kickstarting a new annual event in your community that celebrates diversity.
- Create an Accessible Playground Standard, or update an existing standard for playgrounds that ensures all new playgrounds are built to accessibility standards and create a plan for updating or decommissioning existing playgrounds.
- Create a plan to ensure all town, village and municipal buildings will adhere to the built environment standard before 2030 by prioritizing spaces according to impact.
- Update by-laws to ensure all new builds (government and private) have to adhere to accessibility standards.
- Adopt a Recreation for All policy and commit to ensure equitable access to recreational programs for everyone.
- Adjust the height of everything that needs to be used regularly or in an emergency to an accessible height of 1100mm (ie fire extinguishers, paper towel, soap, etc)
- Ensure there are visual and auditory fire alarms and that emergency plans with muster stations for people in wheelchairs are clearly visible and on each floor.

7.2 Short Term (within 3-6 years) - *These recommendations are actionable items to be implemented based on the immediate recommendations being completed. In 2025 the Municipality, Towns and Villages will conduct a comprehensive review, revisiting community priorities and taking into consideration the goals that have been achieved thus far in addition to the provincial legislative changes. Through this review, the plan, and these proposed short term priorities will be updated.*

- Implement the plan for crosswalks and sidewalk installation and maintenance ensuring accessible, safe, connectivity between amenities and areas of the community.
- Ensure all communication is delivered according to the new accessible communication standard and can exceed the current WCAG standards.
- Ensure all regionally owned built environments have accessible wayfinding, signage, maps, floor plans etc. as outlined in the Accessible Signage Standard.
- Build, replace, update or decommission playgrounds according to the Accessible Playground Standard and implementation plan.
- Ensure all regionally owned built environments foster the feeling of belonging by removing colonial artifacts and increasing representation of diverse communities throughout.
- Ensure public water access in the region's parks have accessible water frontage/access by considering safety and accessible, equitable.
- Connect the main amenities of stores, recreational facilities and outdoor spaces with well lit and clearly marked pathways to encourage the use of the spaces and promote active transportation, aligning with the Active Transportation Plan.
- Start implementing the plan for the built environments in the region to adhere to the built environment standard.
- Promote acceptance by implementing an accessibility policy for all new business/builds or renovations. Provide incentives (tax cuts for certain time periods) for businesses who abide by the policy instead of fining for non-compliance.

7.3 Opportunity Based Recommendations - *These recommendations are meant to build a foundation for continued partnership within the community by engaging with organizations that support people with disabilities and other equity seeking groups. These partnerships will increase capacity and trust within the region.*

- Make available information listing non-profit agencies offering free or affordable assistive devices.
- Promote and support organizations within your community that support and represent all marginalized communities
- Partner with disability support organizations and leverage provincial and federal funding streams to ensure adequate staffing for roles that provide support ie. adequate staffing for day camp and recreation programs in order to accommodate children with disabilities.
- Combine the efforts of the various Municipal, Town and Village Equity, Diversity and Inclusion committees with that of the Regional Accessibility Committee and partner on initiatives.

8.0 Plan Implementation

8.1 About the Recommendations

The recommendations put forth in this plan were done after reviewing policies and documents, performing accessibility audits/environment scans, and numerous methods of community and stakeholder engagement. The recommendations were determined with the following considerations in mind:

- Does the recommendation align with the Provincial goals and legislations?
- Does the recommendation fall within the responsibility of the Municipality, Towns or Villages?
- Does the recommendation address one of the areas that community members and stakeholders identified as one of the more restrictive barriers?
- Is the recommendation achievable in the next two and a half years?

From the recommendations we determined 23 indicators as listed in sections 5.1 through 5.6 of the Standards of Accessibility - Engagement Analysis.

8.2 Monitoring and Evaluation

Indicator tracking and updates will be gathered as part of the RAC work together and will be monitored by the designated Accessibility Coordinator. Indicators are used in order to track accessibility performance. Indicators facilitate the measurement of progress and help identify whether or not the Municipality, Towns and Villages are becoming more accessible through the process. We suggest that indicator information be updated every three months once the process begins. Goals can be set once the Municipality, Towns and Villages have had the opportunity to determine their current statuses. Each area within the region can review their respective areas and bring their statuses to the designated Accessibility Coordinator in an effort to cover a larger area with limited resources. The designated Accessibility Coordinator can then create a mechanism or framework to track the indicators moving forward. Indicators for each standard are defined in their respective sections.

a) Monitoring

The status of the Accessibility Plan's recommendations and indicators will be updated on a quarterly basis and at the end of each fiscal year. Indicator numbers and recommendation completion status should be reported in a report card structure in an effort to be clear and consistent.

b) Schedule

Immediate priorities recorded in section 7.1 above are to be completed between 2022 and the end of the fiscal 2024. In 2025, the Municipality, Towns and Villages will conduct a comprehensive review and update to this plan and its proposed short term priorities in 7.2 This review process should revisit community priorities, taking into consideration the indicators and goals that have been achieved thus far in addition to the provincial legislative changes. This review will reinforce the short term priorities and identify another series of actions to be executed between 2025 and 2030.

c) Evaluation

The needs of the communities in the Municipality, Towns and Villages will continuously change. In an effort to continue to remove and prevent barriers in accessibility the designated Accessibility Coordinator will respond to any external/public questions or complaints around accessibility and ensure that the correct owner of the built environment responds.

Any Municipal accessibility issues or complaints will be forwarded to the designated Accessibility Coordinator. The Accessibility Coordinator will respond to the question or complaint in a timely and respectful manner, but acknowledges that assets are not all under the jurisdiction of the Municipality. Depending on the needs of the individual, the question or complaint will be answered in one of the following ways:

- The Accessibility Coordinator will answer or forward any questions to the appropriate staff member(s) responsible for the Municipal, Town or Village service in question.
- If a staff member requires assistance in obtaining an answer, the RAC will be utilized as a resource at the earliest possible meeting. RAC meets monthly/quarterly.
- Complaints about physical infrastructure as mandated by the Act will be assessed by the Accessibility Coordinator and other departments as necessary.
- Complaints that can be addressed operationally will be forwarded to the responsible department.
- Complaints that require new capital spending will be addressed through the same method of prioritization as other capital projects.
- If a complaint about Municipal or Village staff, goods and services, information, communication or any other category unrelated to the built environment is received, the Accessibility Coordinator will evaluate if actions are already being addressed in an ongoing action.
- Complaints not addressed in an ongoing action will be brought forward to the RAC for discussion for suggestions on reaching a potential resolution.
- Solutions may be proposed immediately, or may be suggested in the updated action plan in 2025.
- Anyone can ask to be heard at a meeting of the Regional Accessibility Committee or Council if they are not satisfied with the response received by the designated Accessibility Coordinator.

GRATITUDE:

This report was made possible with much appreciation for the foresight and commitment to change by the Administration, Senior Management, Council, Regional Accessibility Committee and the community as a whole in the Truro-Colchester Region, past and present.

Many thanks to Truro-Colchester Region Staff.

We are very appreciative of the time the Truro-Colchester Region teams have taken to accommodate us during the review as well as to the members of the community who engaged us in discussions regarding making their communities accessible and inclusive.

We have listed a number of resources in the appendices for you to refer to for quick reference. We would love to continue to work with the Truro-Colchester Region to help you obtain the training needed to not only operate with best practice but to be leaders in next practice.

We have learned an endless amount from working on this project with you and we hope to work with the Province of Nova Scotia and the Accessibility Directorate to help create change within the provincial policies. We wish you all the very best with this process and look forward to watching change happen within the Truro-Colchester Region as you move accessibility forward.

Sincerely,

Jessica Ward
Program and Project Manager
On behalf of the entire reachAbility Association team

9.0 APPENDIX

9.1 GLOSSARY OF TERMS

Accessibility: The prevention and removal of barriers (physical, attitudinal, technological, or system) to allow equitable participation for persons with disabilities or others who experience barriers to accessibility.¹

Accessibility Act: The provincial legislation enacted in 2017 to prevent and remove barriers to accessibility for people with disabilities. It has a goal of an accessible Nova Scotia by 2030. The Act outlines some responsibilities for municipalities, universities, and other entities, including developing accessibility plans and establishing an accessibility committee. It allows the Government to develop and implement standards (regulations) in education, the built environment, the delivery and receipt of goods and services, transportation, information, communication, and employment.¹

Accessible Customer Service: Ensuring all persons have the same opportunity to seek, obtain, use or benefit from the service. Accessible services are easy for all people to use, interact with, and understand.¹

Barrier: Anything that hinders or challenges the full and effective participation in society. Barriers can be physical, attitudinal, technological, or systemic (policy or practice). Accessibility barriers may be related to areas such as employment, education, the built environment, transportation, the delivery and receipt of goods and services, or information and communications.¹

Barrier-Free: A barrier-free environment is one which enables people with disabilities to move about safely and freely and use all facilities within the built environment, roads, parks, gardens and other places.

Communication Access Real-Time (CART): The professionally translated transcription of speech to text through a third party. It enables culturally Deaf, oral deaf, deafened and hard of hearing people to have visual access to the spoken word. CART services can be provided on-site or remotely.⁸

Deaf: A sociological term referring to those individuals who are medically deaf or hard of hearing who identify with and participate in the culture, society, and language of Deaf people, which is based on Sign language.³

Disability: A physical, mental, intellectual, learning or sensory impairment, including an episodic disability, that, in interaction with a barrier, hinders an individual's full and effective participation in society.^{3,1}

Equity/Equitable: Equity is fair treatment of individuals, acknowledging and making provisions for their differences by ensuring that employment and educational processes are free from systemic barriers. Equity does not mean ignoring differences and treating everyone the same. Instead it means recognizing and valuing differences, removing systemic barriers and accommodating individual differences, as needed.⁴

First Voice: First voice perspectives generally refer to the knowledge generated by persons with disabilities and others who experience barriers to accessibility that emerges from lived experience, community connections, knowledge traditions, and scholarly activities that are typically undervalued and under-represented.¹

Inclusion: The process of improving the terms of participation in society, particularly for individuals or groups of individuals who are disadvantaged or under-represented, through enhancing opportunities, access to resources, voice and respect for rights. This creates a sense of belonging, promotes trust, fights exclusion and marginalization and offers the opportunity of upward mobility and results in increased social cohesion.⁵

9.1 GLOSSARY OF TERMS (cont'd)

Marginalized Populations: Groups and communities that experience discrimination and exclusion (social, political and economic) because of unequal power relationships across economic, political, social and cultural dimensions.¹¹

Meaningful Access: When referring to the built environment, meaningful access is the intent to meet the needs of all users of a site (a building or outdoor space) regardless of their ability. It means that not only individual features of a site, such as an entrance or washroom, must be accessible, but the entire experience throughout.¹

Regional Accessibility Committee (RAC): The joint Accessibility Committee formed by the Towns of Truro and Stewiacke, the Villages of Bible Hill and Tatamagouche, and the Municipality of Colchester which advises Council on the elimination of barriers faced by people with disabilities and acts as a liaison with external bodies on barriers to participation in public life and to the achievement of social, cultural and economic well-being of people with disabilities.

Rick Hansen Foundation Accessibility Certification (RHFAC): A national rating system that measures and certifies the level of meaningful access of buildings and sites. It measures the level of meaningful access beyond building code, and is based upon the holistic user experience of people with varying disabilities affecting their mobility, vision, and hearing.⁷

Universal Design: Universal Design is the design and composition of an environment so that it can be accessed, understood and used to the greatest extent possible by all people regardless of their age, size, ability or disability.⁷

Universal Design for Learning (UDL): An educational approach to designing instructional goals, assessments, methods and materials, and policies that work for a diversity of learners. It employs flexible approaches that can be customized and adjusted for individual student needs.¹

References

¹ Nova Scotia Post Secondary Framework

³ Nova Scotia Accessibility Act

⁵ Nova Scotia Community College Educational Equity Policy

⁶ Scorgie, K. & Forlin, C. (2019). Promoting Social Inclusion: Co-Creating Environments that Foster Equity and Belonging. P. 153.

⁷ Rick Hansen Foundation

⁸ Canadian Hearing Services

¹¹ National Collaborating Centre for Determinants of Health

9.2 STAIRS

As the Built Environment Standard for the Nova Scotia Accessibility Act (Bill 59) is still under development we recommended following the standard set out by the National Standard of Canada in B651-18, Accessible Design for the Built Environment. For all aspects of stairs, we recommend the Truro-Colchester Region refer to section 5.4 of the National Standard for examples, some of which we have included below.

5.4 Stairs

5.4.1 Treads and risers

A flight of stairs shall

- a) have uniform riser heights and tread depths;
- b) have risers not more than 180 mm high;
- c) have treads that are slip resistant;
- d) have treads not less than 280 mm deep, measured from riser to riser;
- e) have no open risers [see Figure 27 c)];
- f) be illuminated to at least 50 lx at the tread; and
- g) have a horizontal strip at the edge of the tread that
 - i) is 50 ± 10 mm deep;
 - ii) is colour-contrasted with the tread and riser; and
 - iii) extends the full width of the tread.

5.4.2 Nosing

The nosing shall

- a) project not more than 38 mm;
- b) have no abrupt undersides [see Figure 27 d)];
- c) have a radius of curvature at the leading edge of the tread not more than 13 mm;
- d) where projecting, be sloped to the riser at an angle greater than 60° to the horizontal [see Figure 27 a)]; and
- e) have a horizontal strip 50 ± 10 mm deep that
 - i) is colour-contrasted with the tread and riser; and
 - ii) extends the full width of the tread.

9.2 STAIRS (cont'd)

5.4.3 Tactile attention indicator surfaces at stairs

5.4.3.1 General

A tactile attention indicator surface shall

- a) comply with Clauses 4.3.5.2 and 4.3.5.3;
- b) be located at the top of stairs;
- c) be continuous across the width of the stair with a maximum gap of 75 mm to the stringer or end of tread; and
- d) have a length between 600 and 650 mm, commencing one tread depth from the edge of the stair [see Figures 5 b) and 27 b)].

5.4.3.2 Location

A tactile attention indicator surface shall be provided

- a) at stairs that are not enclosed;
- b) at each landing incorporating an entrance into a stair system;
- c) where the regular stairway pattern is broken; and
- d) where the run of a landing with no continuous handrail is greater than 2100 mm.

Figure 27
Stair detail
(See Clauses 5.4.1 – 5.4.3.)

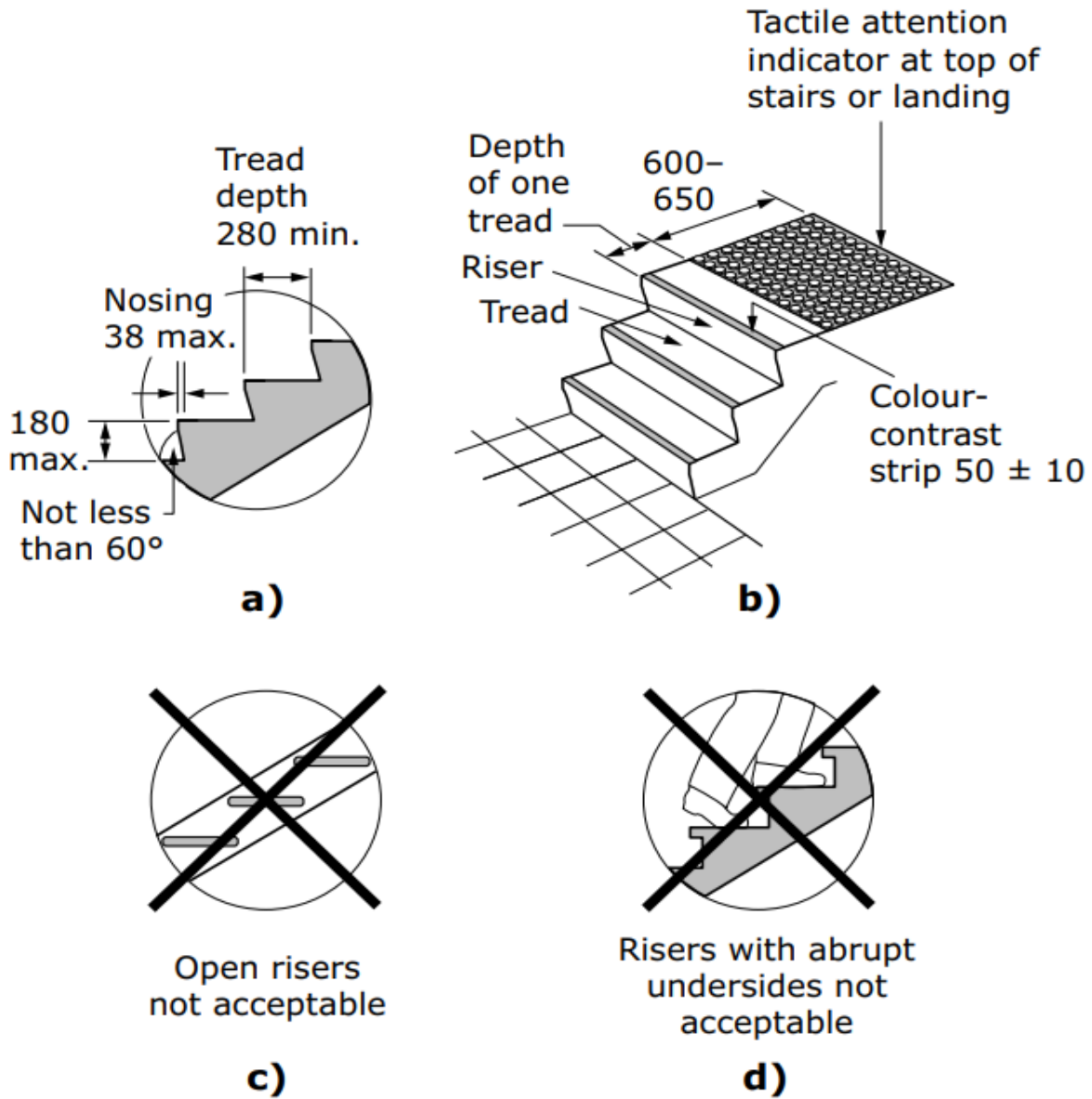

Note: All dimensions are in mm.

9.2 STAIRS (cont'd)

5.4.4 Stair handrails

Handrails shall be provided for stairs and shall

- a) comply with Clause 5.3;
- b) be installed on both sides of the stairs (see Figure 28);
- c) be of uniform height, from 860 to 920 mm, measured vertically from the leading edge of the tread;
- d) be continuous around landings less than 2100 mm in length, except where the landing
 - i) is intersected by an alternative path of travel; or
 - ii) has an entry door leading onto it;
- e) be continuous where located on the inside edge of the stairs (see Figure 29);
- f) at the top of the stairs, extend at least 300 mm parallel to the floor surface (see Figure 31);
- g) at the bottom of the stairs, continue to slope for a distance equal to the depth of one tread and then extend at least 300 mm parallel to the floor surface (see Figure 30); and
- h) have the rail extension return to the post, floor, or wall (see Figures 28, 30, and 31).

9.2 STAIRS (cont'd)

Figure 28
Stair handrails
(See Clause 5.4.4.)

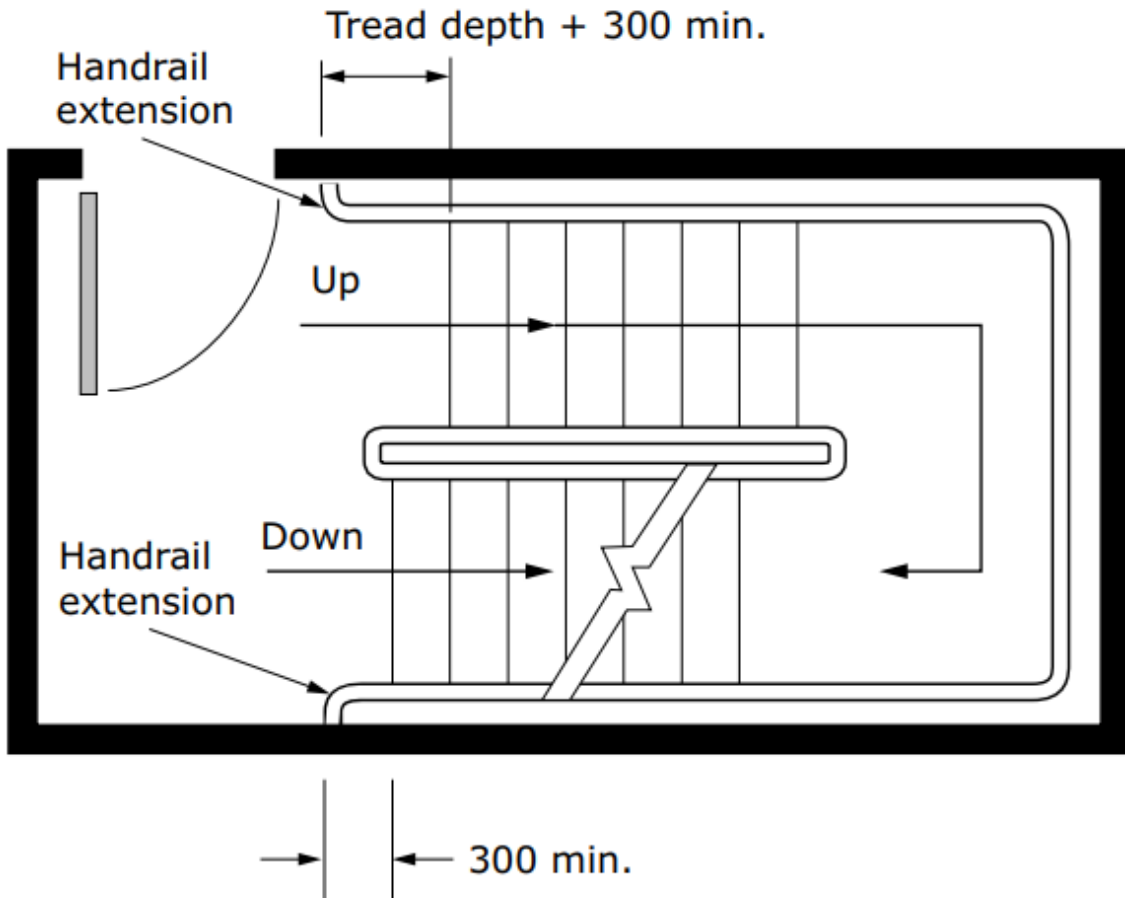

Note: All dimensions are in mm.

Figure 29
Continuous inside handrail at stairs
(See Clause 5.4.4.)

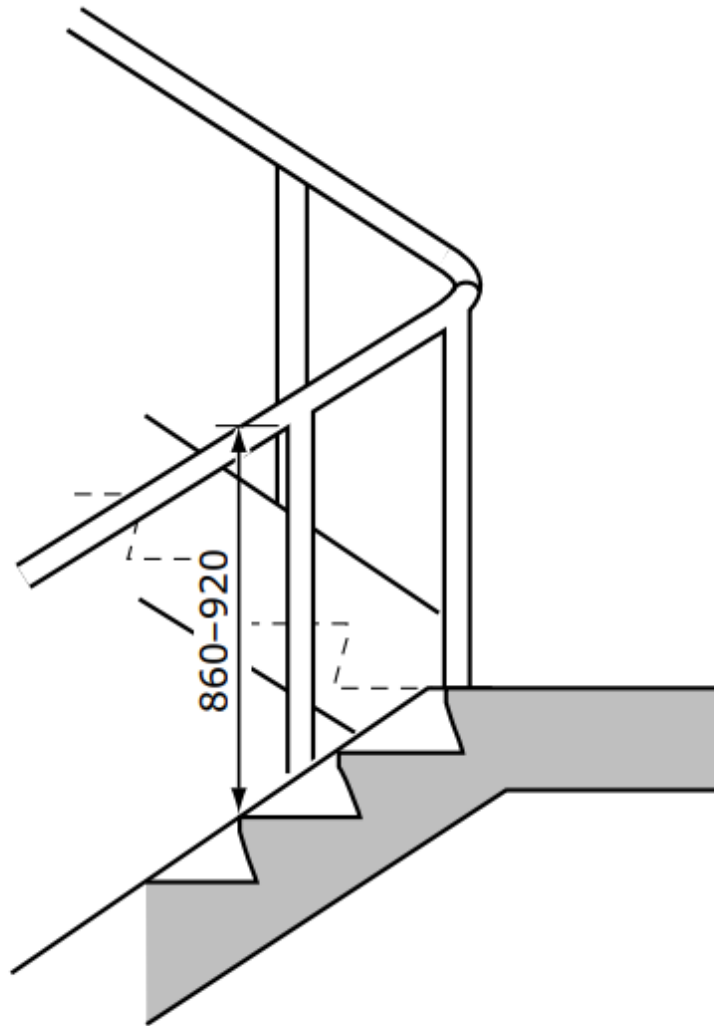

Note: All dimensions are in mm.

Figure 30
Handrail extension at bottom of stairs
(See Clause 5.4.4.)

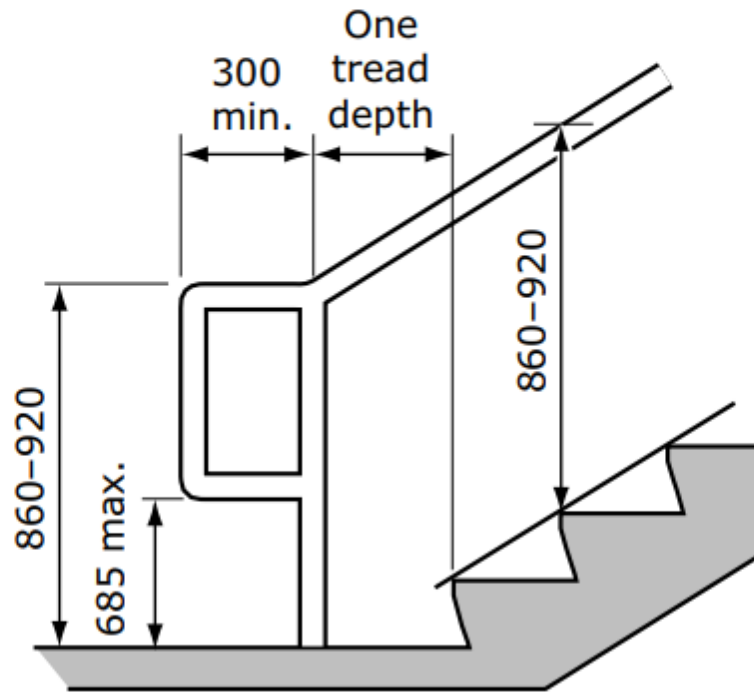

Note: All dimensions are in mm.

Figure 31
Handrail extension at top of stairs
(See Clause 5.4.4.)

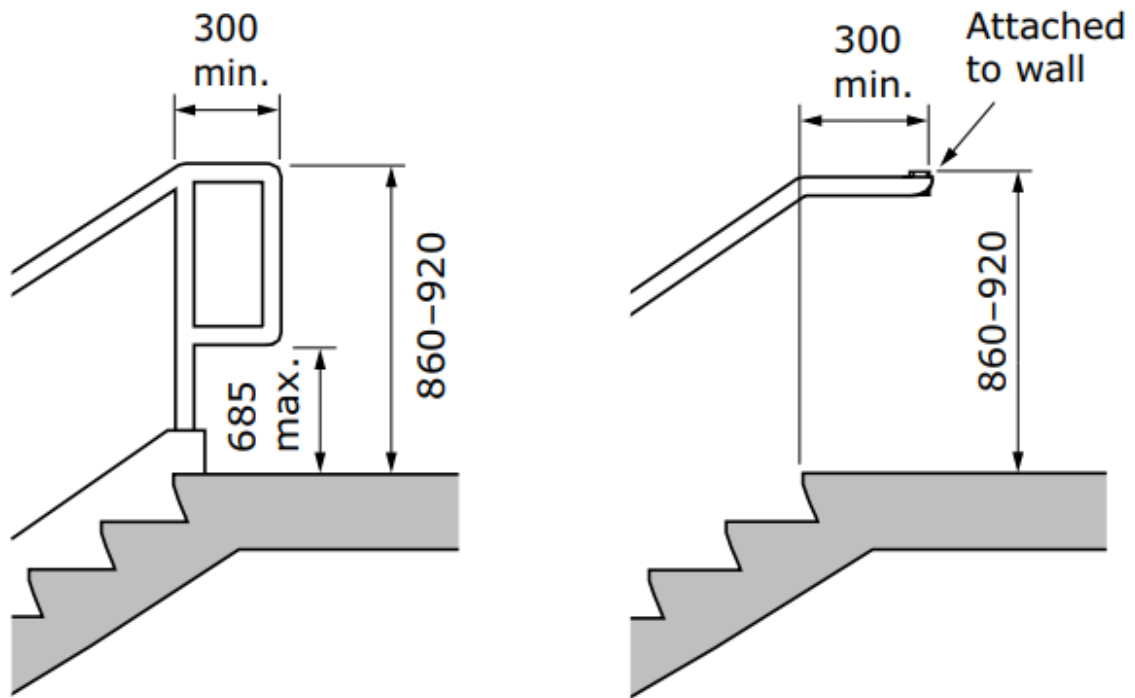

Note: All dimensions are in mm.

9.3 ACCESSIBLE INTERIOR ROUTES

As the Built Environment Standard for the Nova Scotia Accessibility Act (Bill 59) is still under development we recommended following the standard set out by the National Standard of Canada in B651-18, Accessible Design for the Built Environment. For all aspects of accessible routes, we recommend the Truro-Colchester Region refer to section 5.1 of the National Standard for examples, some of which, we have included below.

5.1 Accessible routes

5.1.1 Width

The clear width of accessible routes shall be at least 1000 mm with the following exceptions:

- a) for short indentations up to 600 mm in length, it shall be at least 850 mm [see Figure 14 a)];
- b) for doorways, it shall be at least 850 mm, though additional manoeuvring space is sometimes required (see Clause 5.2);
- c) for U-turns around an obstacle less than 1200 mm wide, it shall be at least 1100 mm [see Figure 16 a)];
- d) for U-turns around an obstacle greater than 1200 mm wide, it shall be at least 1000 mm [see Figure 16 b)];
- e) an accessible path of travel that is more than 30 m long shall have a maneuvering zone at least 1700 mm wide for a length of 1700 mm at intervals not exceeding 30 m; and
- f) for checkout lanes, the minimum width should be 1000 mm (see Figure 15).

5.1.2 Slope

Accessible routes shall

- a) have a running slope not exceeding the ratio of 1:20 (5%);
- b) where necessary for a slope to exceed the ratio of 1:20 (5%), be designed as
 - i) a ramp complying with Clause 5.5; or
 - ii) a curb ramp, where accessing a vehicular path of travel, complying with Clause 8.3.3; and
- c) have a cross slope not exceeding the ratio of 1:50 (2%).

Figure 14
Width of interior accessible routes
(See Clause 5.1.1.)

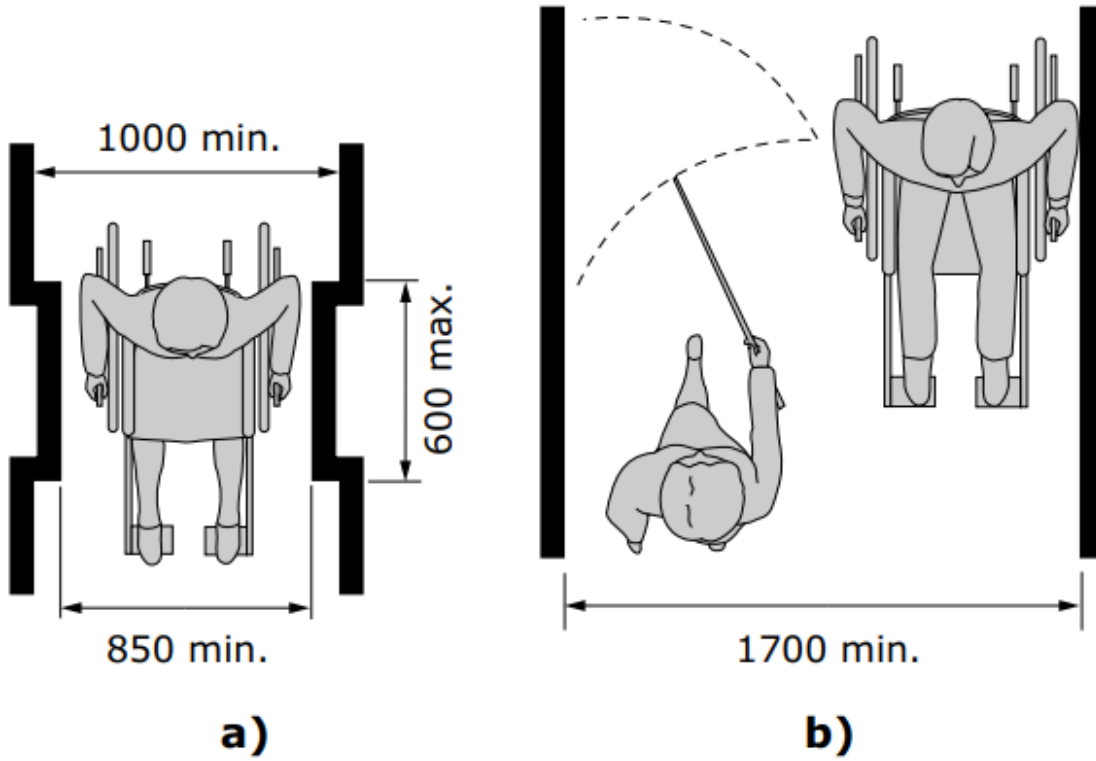

Note: All dimensions are in mm.

9.3 ACCESSIBLE INTERIOR ROUTES (cont'd)

Figure 15
Width of accessible checkout lanes
(See Clause 5.1.1.)

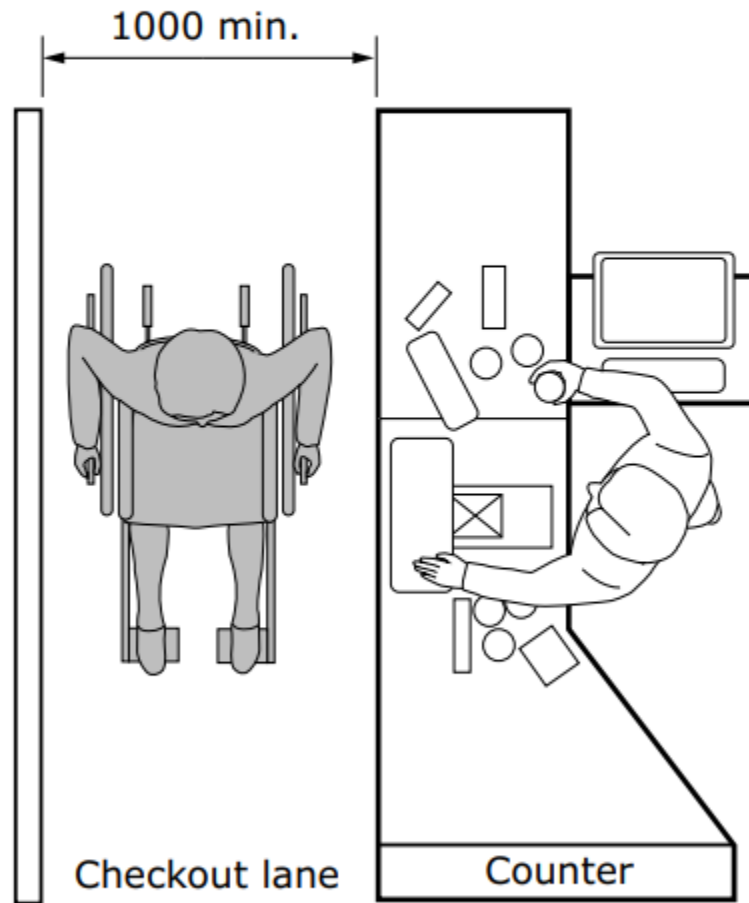

Note: All dimensions are in mm.

Figure 16
Width of accessible route around an obstacle
(See Clause 5.1.1.)

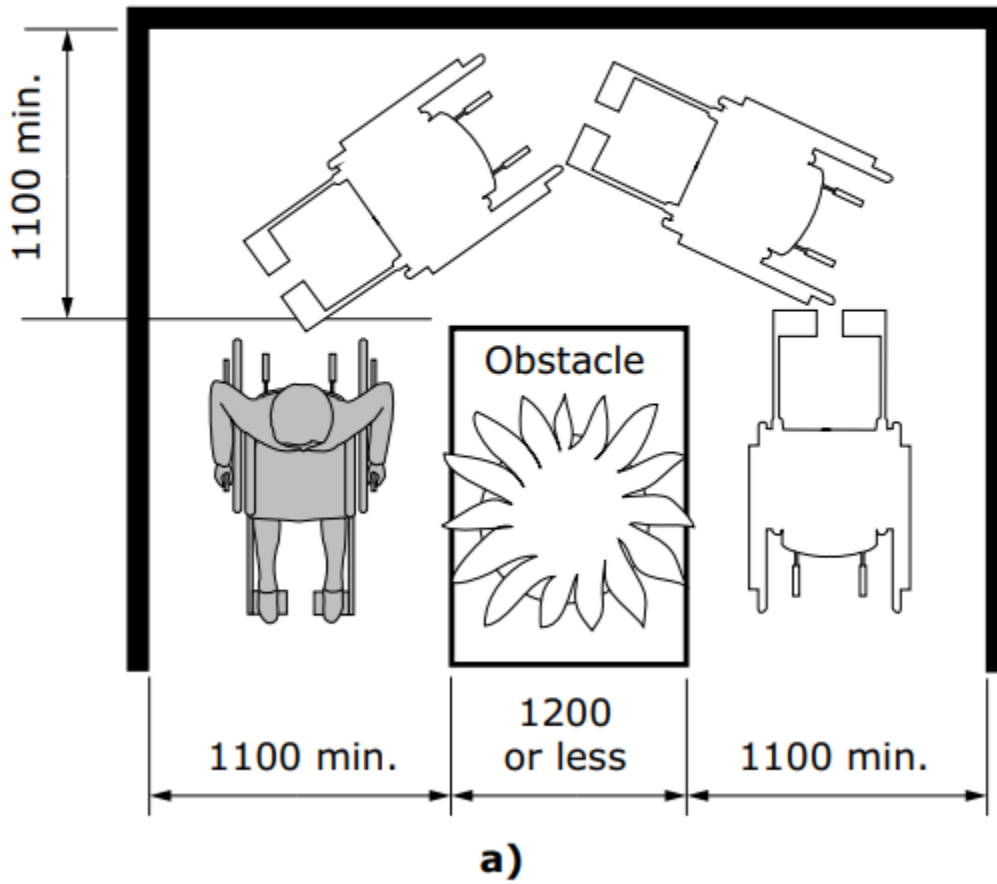

9.3 ACCESSIBLE INTERIOR ROUTES (cont'd)

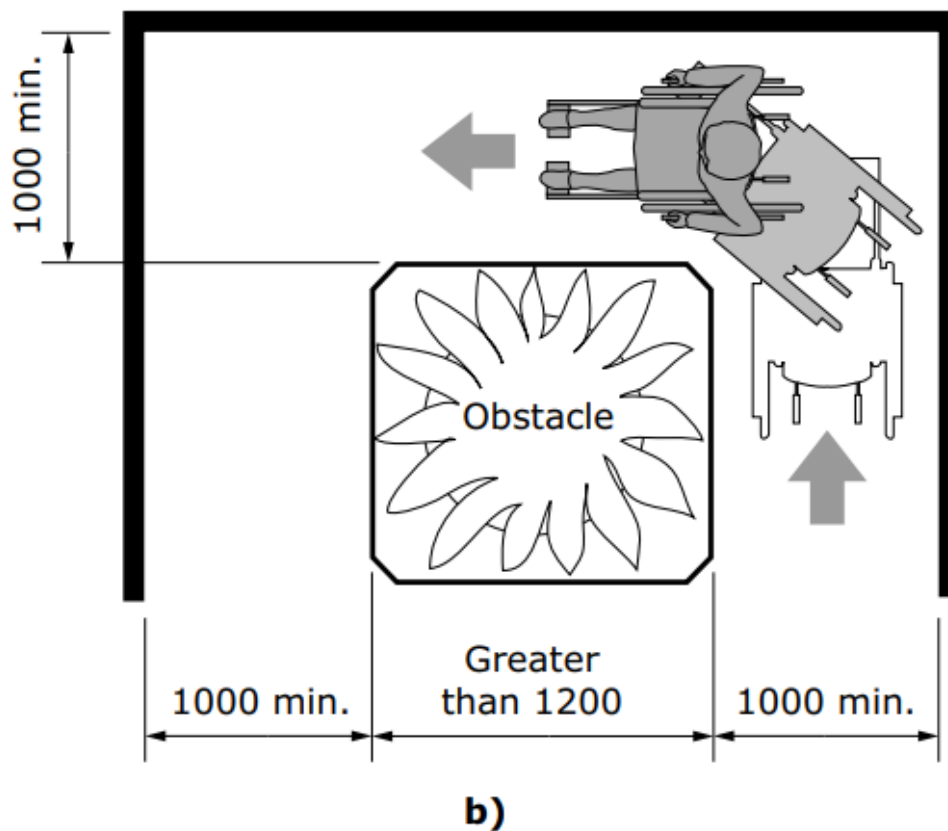

Note: All dimensions are in mm.

5.1.3 Lineup guides

Lineup guides shall

- be separated by a clear width of at least 1000 mm (see Figure 17);
- have a clear floor area of at least 1700×1700 mm where lineups change direction and where they begin and end;
- be cane-detectable at or below 685 mm from the floor;
- be stable and not move easily;
- be colour-contrasted with their surroundings; and
- have a glare-free finish.

Figure 17
Lineup area
(See Clause 5.1.3.)

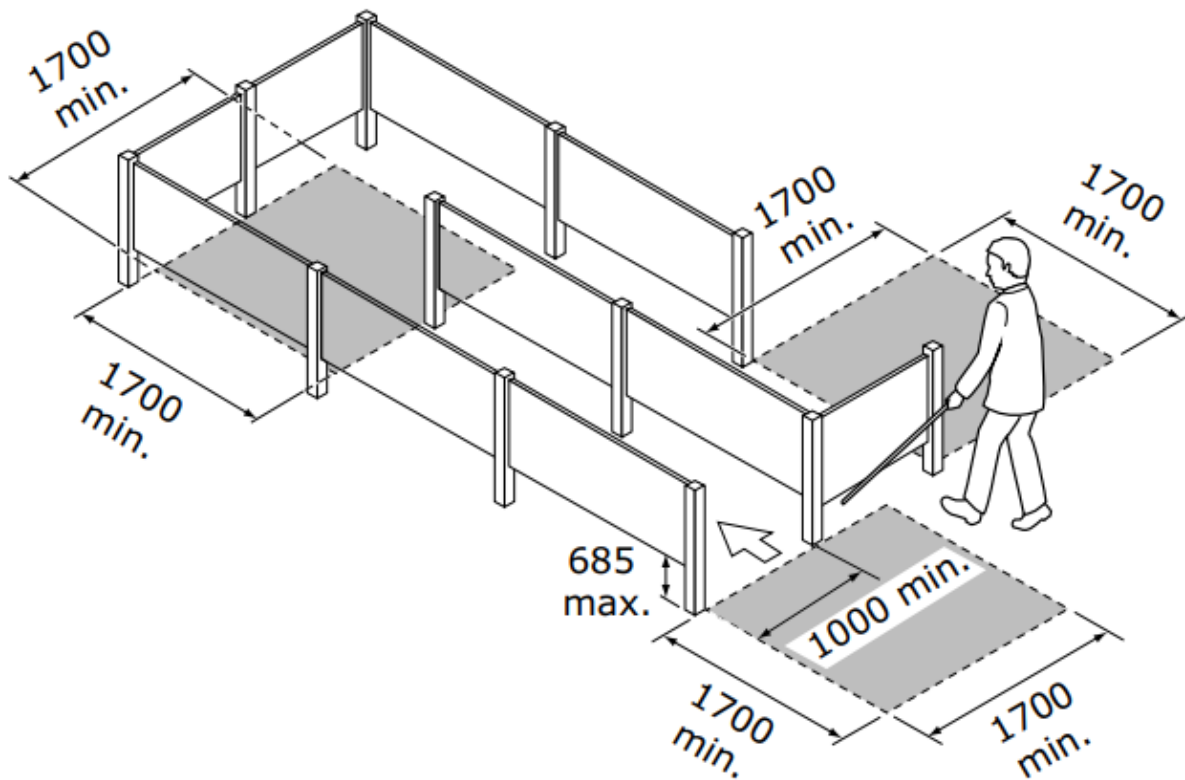

Note: All dimensions are in mm.

5.1.4 Safety

Accessible routes including accessible egress routes shall

- a) have walking surfaces that comply with Clause 4.3;
- b) comply with Clause 4.4 for headroom where protrusions exist;
- c) comply with Clause 5.3 where handrails are provided; and
- d) be kept unobstructed and comply with Clause 4.4.2.3.

9.4 PARKING

As the Built Environment Standard for the Nova Scotia Accessibility Act (Bill 59) is still under development we recommended following the standard set out by the National Standard of Canada in B651-18, Accessible Design for the Built Environment. For all aspects of designated accessible parking, we recommend the Truro-Colchester Region refer to section 9.4 of the National Standard for examples, some of which, we have included below.

9.4 Designated accessible parking

9.4.1 Area allowances

A designated accessible parking space shall

- a) be at least 2600 mm wide;
- b) have an adjacent side access aisle at least 2000 mm wide (see Figure 71); and
- c) have an adjacent rear access aisle at least 2000 mm long (see Figure 72).

Table 7
Recommended number of designated parking spaces
(See Clause 9.4.1.)

Number of designated parking spaces (see Clause 9.4.1)	Number of designated accessible parking spaces (see Clause 9.4)	Number of designated limited mobility parking spaces (see Clause 9.5)
2-50	1-3	2-6
51-100	2-4	4-8
101-200	4-8	8-16
201-300	5-10	10-20
301-500	6-12	12-24
Over 500	6-12 plus 1-3 for every 100 spaces over 500	12-24 plus 2-6 for every 100 spaces over 500

9.4 PARKING (cont'd)

9.4.2 Height allowances

The clearance from the pavement to the underside of any ceiling structure or hanging object shall be at least 2750 mm

- a) along the vehicular route; and
- b) at the designated accessible parking space(s) (see Figure 69).

9.4.3 Surface

A designated parking space and its adjacent side aisle shall

- a) have a surface that is level, stable, firm, and slip-resistant;
- b) on the side access aisle, have diagonal markings that resist fading or removal; and
- c) where bollards or curbs separate the vehicular area from a pedestrian route, have them comply with Clause 8.3.9.

9.4 PARKING (cont'd)

9.4.4 Signage for designated accessible parking

9.4.4.1 Identification

A designated accessible parking space shall be identified by

- a) a vertically mounted sign; and
- b) the International Symbol of Access painted on the pavement (see Figure 12).

9.4.4.2 Vertical signs

A vertical sign shall

- a) be at least 300 mm wide × 450 mm high;
- b) have the centre of the sign between 1500 to 2000 mm from the ground;
- c) incorporate the International Symbol of Access (see Figure 12); and
- d) comply with Clause 4.4.

9.4.4.3 Pavement signs

A painted sign on the pavement shall

- a) be located in the centre of the parking space; and
- b) have the International Symbol of Access (see Figure 12)
 - i) at least 1000 mm long; and
 - ii) colour-contrasted with the background pavement.

9.5 Designated accessible parking spaces for limited mobility users

Where provided as a courtesy, a designated accessible car space for users with limited mobility shall be

- a) at least 2400 mm wide; and
- b) identified by a sign for limited mobility access.

Figure 71
Perpendicular accessible parking space
(See Clause 9.4.1.)

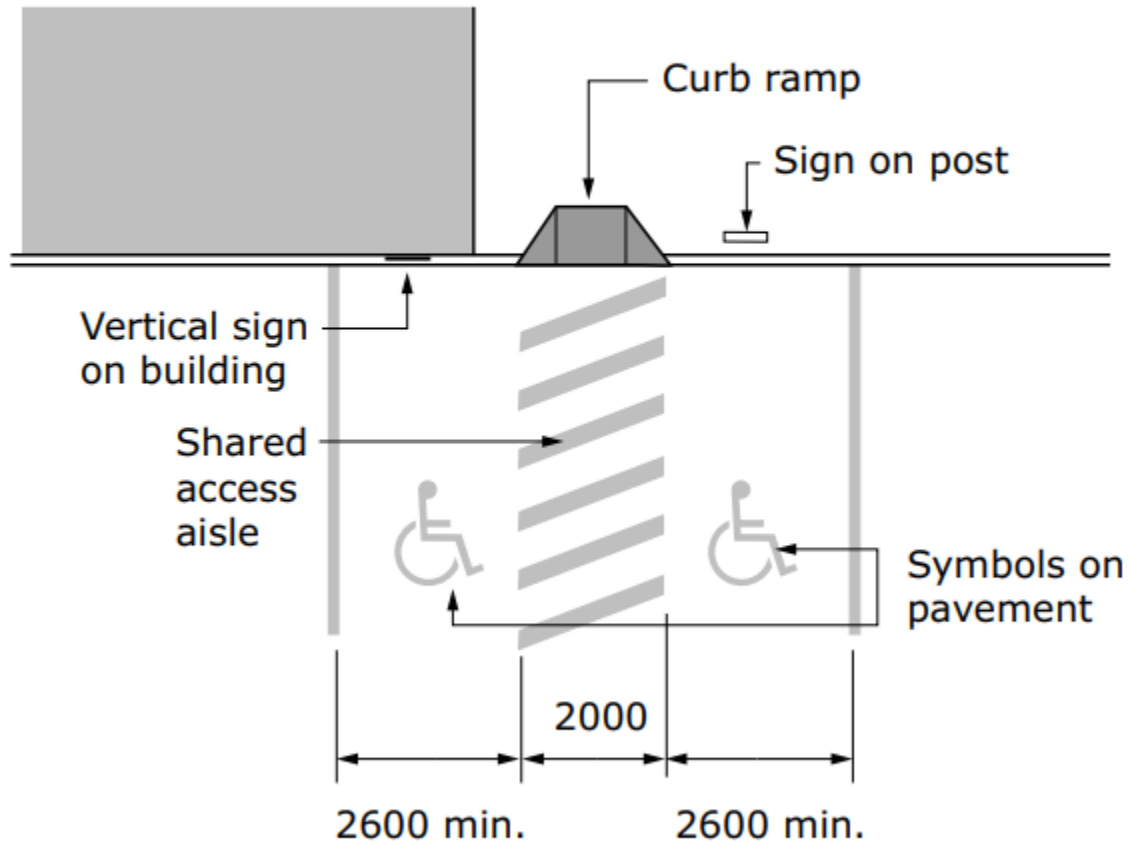

Note: All dimensions are in mm.

Figure 72
Parallel accessible parking space
(See Clause 9.4.1.)

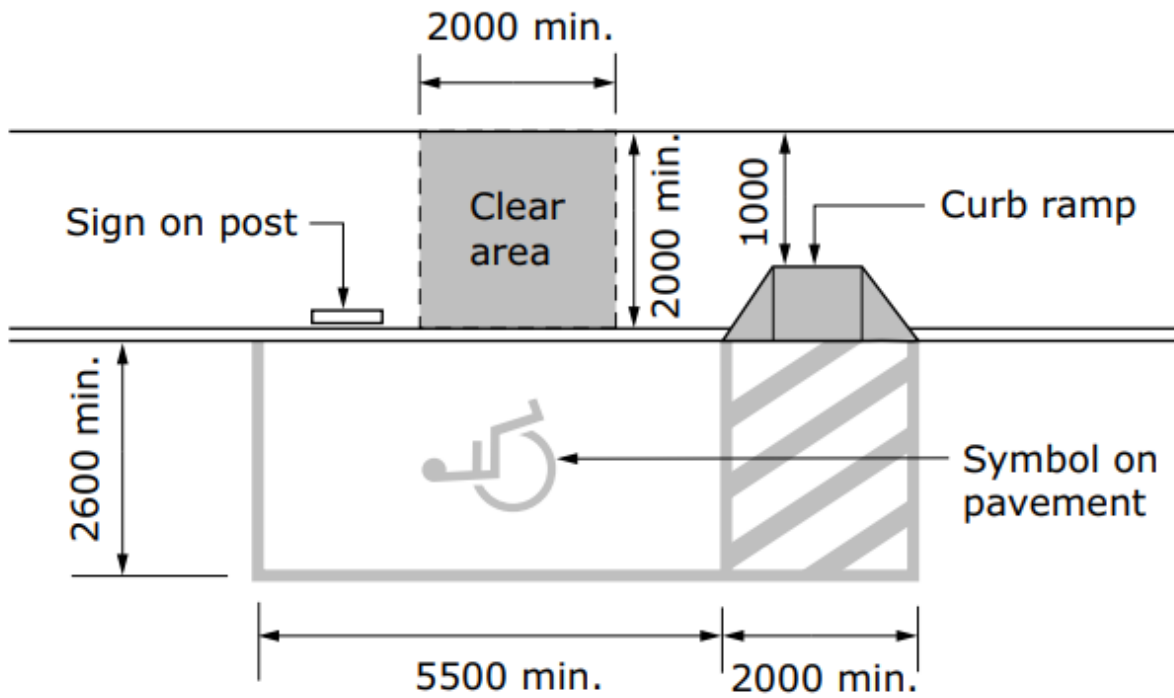

Note: All dimensions are in mm.

9.5 RAMPS

As the Built Environment Standard for the Nova Scotia Accessibility Act (Bill 59) is still under development we recommended following the standard set out by the National Standard of Canada in B651-18, Accessible Design for the Built Environment. For all aspects of ramps, we recommend the Truro-Colchester Region refer to section 5.5 of the National Standard for examples, some of which, we have included below.

5.5 Ramps

5.5.1 Running slope and length

A ramp shall have

- a) a running slope with the ratio between 1:12 (8.33%) and 1:20 (5%); and
- b) a horizontal distance between level landings not greater than 9000 mm.

5.5.2 Cross slope

The cross slope of the ramp surface shall not be steeper than the ratio of 1:50 (2%).

9.5 RAMPS (cont'd)

5.5.3 Width

The clear width on a ramp shall be at least 1000 mm.

5.5.4 Landings

A level landing shall

- a) be provided at the top and bottom of each ramp;
- b) be provided at all changes of ramp direction;
- c) be at least as wide as the widest ramp leading to it;
- d) have a length not less than 1500 mm;
- e) at doorways serving an accessible route, have an area of at least 1700 × 1700 mm;
- f) include passing spaces with an area of at least 1700 x 1700 mm
 - i) at the connection points when more than two ramp segments are used to surmount a level change; and
 - ii) at the turning point when a turn separates two ramp segments; and
- g) where it meets a slope change, have a 50 ± 10 mm wide colour-contrasted and slip-resistant strip equal to the width of the ramp.

9.5 RAMPS (cont'd)

Figure 32
Ramp slope
(See Clauses 5.5.1 and 8.2.7.)

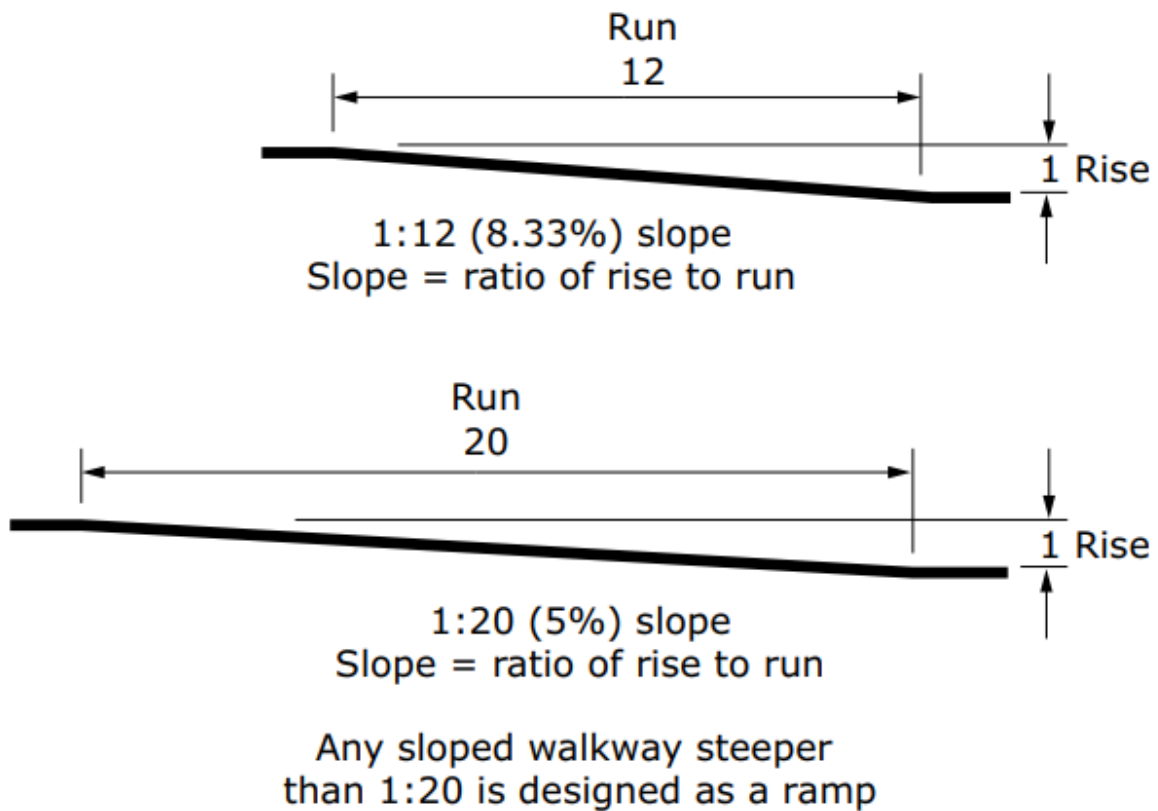

Note: All dimensions are in mm.

Figure 33
Ramps and landings
(See Clauses 5.5.4 and 8.2.7.)

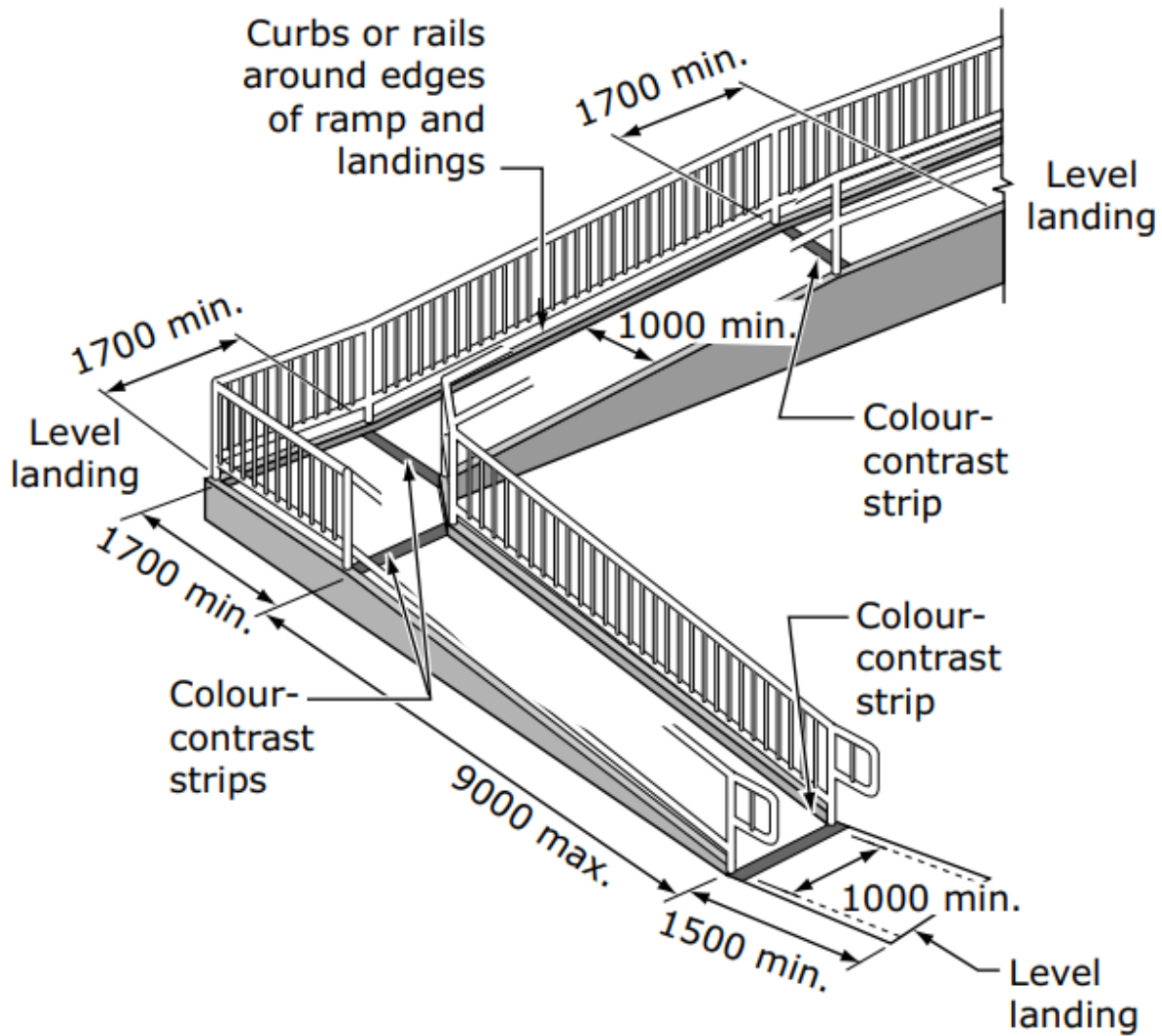

a) Intermediate landings with a sharp turn

9.5 RAMPS (cont'd)

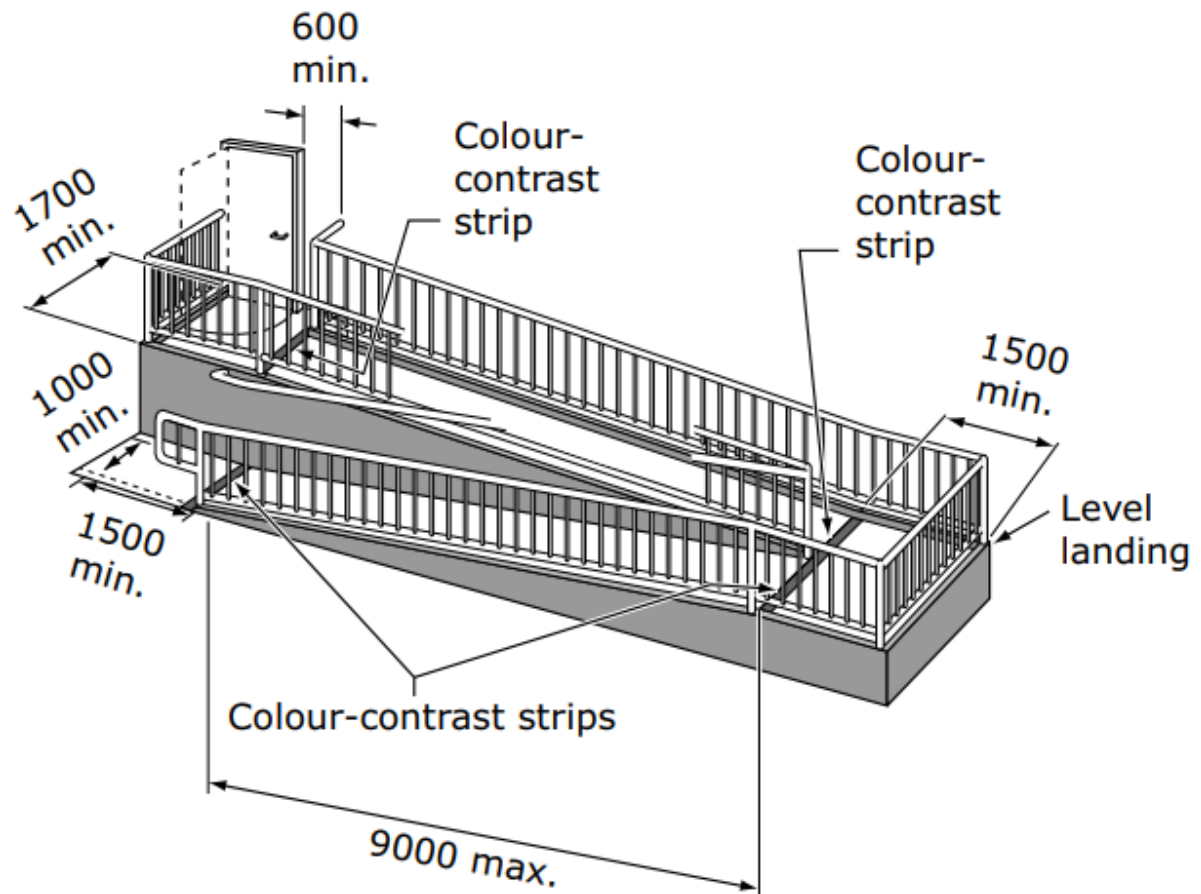

b) Doorways at landings

Notes:

- 1) Handrails have been partially omitted for clarity.
- 2) All dimensions are in mm.

9.5 RAMPS (cont'd)

5.5.5 Surfaces

A ramp and landing surface shall comply with Clause 4.3.1.

5.5.6 Edge protection

On ramps and landings that are not at grade or adjacent to a wall, protection shall be provided on all edges in the form of either

- a) a curb with a minimum height of 100 mm [see Figure 34 a)];
or
- b) a raised barrier or rail with its lower edge not more than 100 mm from the ramp or landing surface [see Figure 34 b) and c)].

Figure 34
Ramp edge protection
(See Clauses 5.5.6 and 8.2.7.)

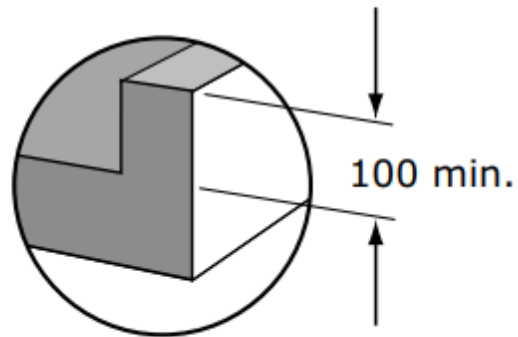

a)

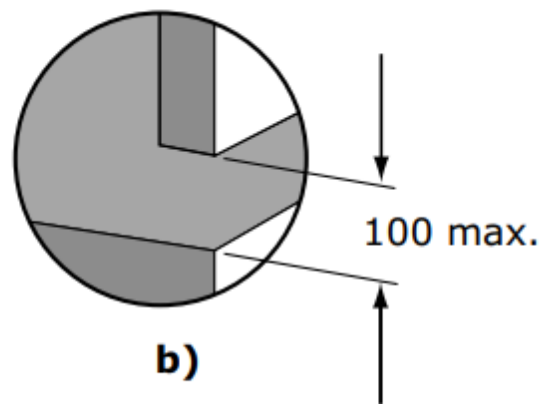

b)

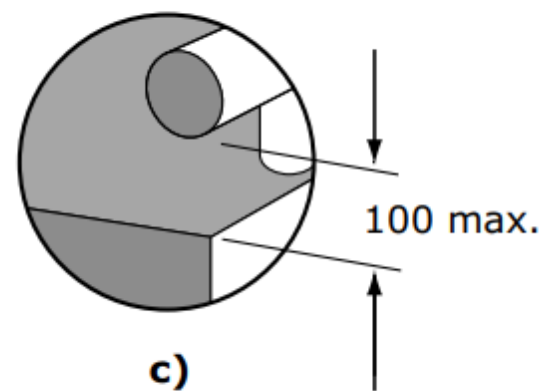

c)

Note: All dimensions are in mm.

9.5 RAMPS (cont'd)

5.5.7 Illumination

Illumination at the surface level of a ramp and its landings shall be at least 50 lx.

5.5.8 Ramp handrails

Ramps shall have handrails on both sides that

- a) comply with Clause 5.3;
- b) are continuous on the ramp and around landings;
- c) are colour-contrasted with their surroundings;
- d) have at least one set of handrails with a clear width between 920 and 1000 mm between the rails;
- e) have a height between 860 and 920 mm, measured from the ramp surface to the top of the rail; and
- f) have horizontal extensions beyond the top and bottom of the ramp
 - i) at least 300 mm long; and
 - ii) that are returned to the post, floor, or wall (see Figure 35).

Figure 35
Ramp handrail extensions
(See Clause 5.5.8.)

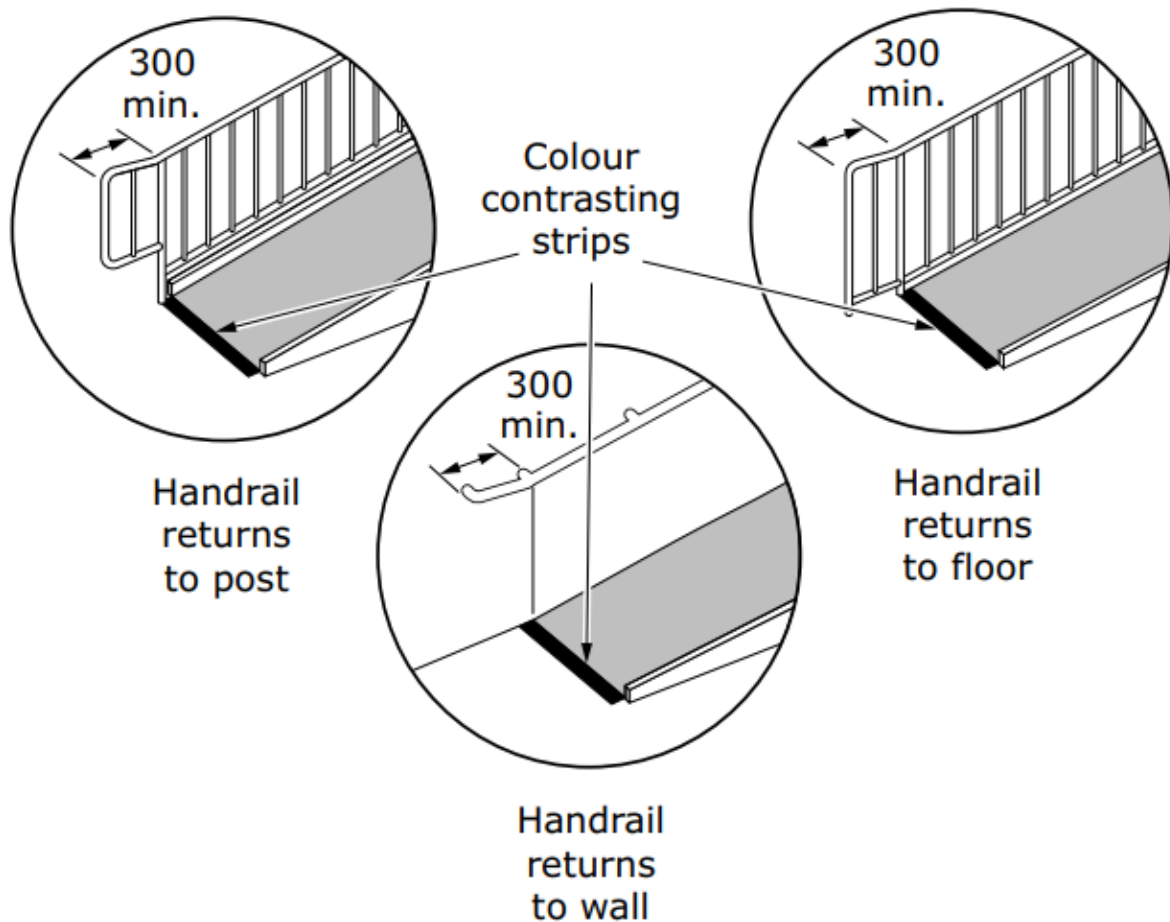

Note: Near handrail omitted for clarity.

Notes:

- 1) Near handrail omitted for clarity.
- 2) All dimensions are in mm.

9.6 WASHROOMS

As the Built Environment Standard for the Nova Scotia Accessibility Act (Bill 59) is still under development we recommended following the standard set out by the National Standard of Canada in B651-18, Accessible Design for the Built Environment. For all aspects of washrooms, we recommend the Truro-Colchester Region refer to section 6.2 of the National Standard for examples, some of which, we have included below.

Figure 40
Example of a washroom layout
(See Clauses 6.2.2 and 6.2.7.2.)

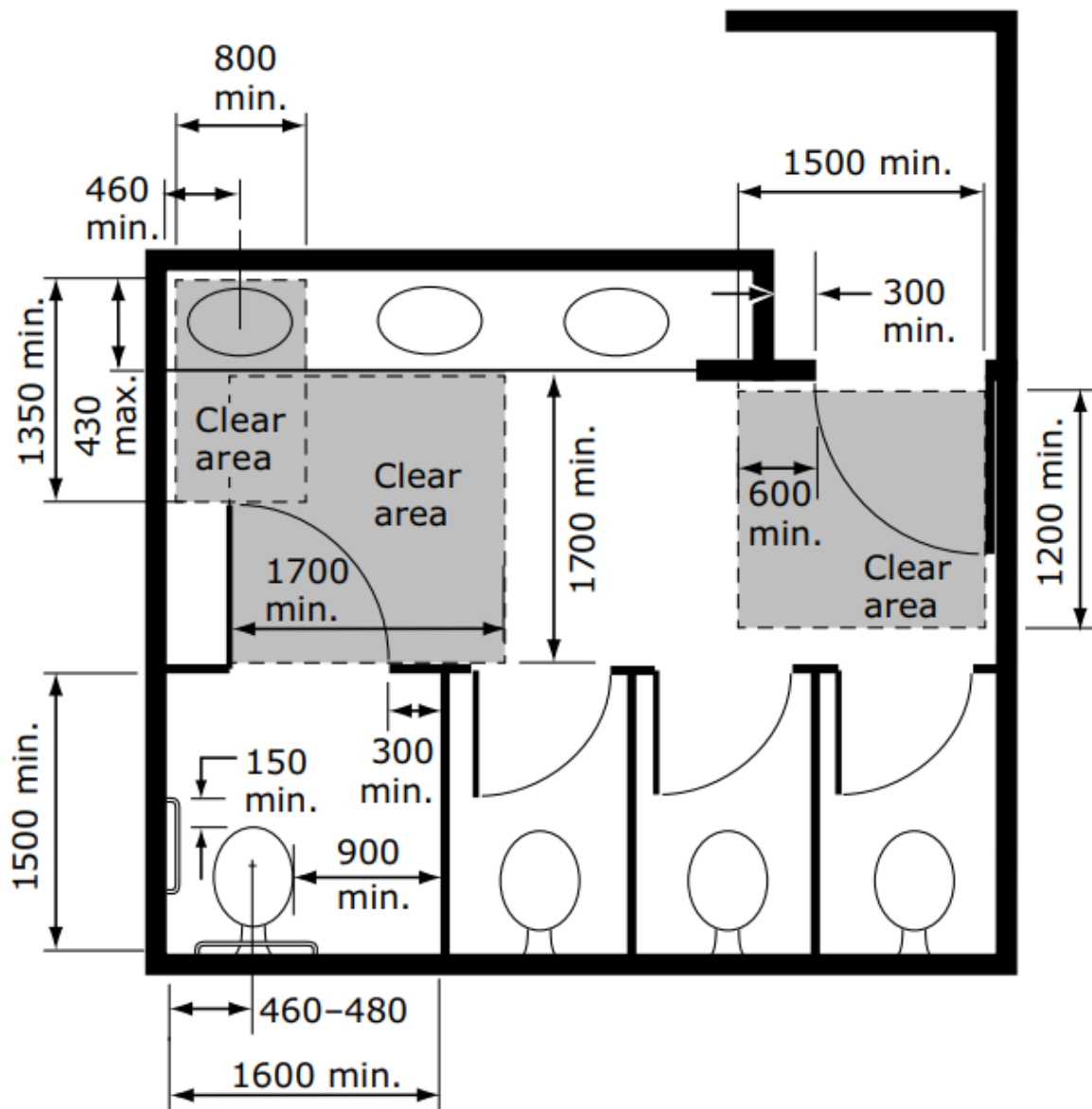

Note: All dimensions are in mm.

9.6 WASHROOMS (cont'd)

6.2 Washroom facilities

6.2.1 Identification

Signs at washroom entrances shall

- a) comply with Clause 4.5;
- b) not be mounted on a door;
- c) if there is no door, be mounted on the outside walls, on both sides of the entrance opening; and
- d) if the washroom is not accessible, indicate the location of the nearest accessible washroom.

6.2.2 Floor area

A clear floor area for maneuvering shall be provided

- a) at the door, if there is one, that complies with Clause 5.2.2;
and
- b) in the interior, at least 1700 × 1700 mm in front of the accessible stall (see Figure 40).

9.6 WASHROOMS (cont'd)

6.2.3.2 Lavatory counters

A lavatory counter with a front apron shall have a knee clearance centred on the lavatory at least 800 mm wide × 685 mm high [see Figure 41 a) and b)].

6.2.3.3 Faucets

Faucets and other controls shall

- a) comply with Clause 4.2;
- b) not require the application of continuous force to maintain water flow; and
- c) where metered, provide at least 10 s of flow.

6.2.3.4 Water temperature

The temperature of the water supplied to the lavatory shall not exceed 49 °C.

6.2.4 Washroom accessories

6.2.4.1 Operation

The operable parts and controls of at least one of each type of washroom accessory shall comply with Clause 4.2.

6.2.4.2 Mirrors

A mirror shall be mounted with its bottom edge not more than 1000 mm from the floor (see Figure 42).

6.2.4.3 Soap dispensers

Where a soap dispenser is provided at the accessible lavatory, it shall be

- a) located within a 500 mm reach of a person seated at the lavatory;
- b) located with the dispensing point no higher than 1100 mm; and
- c) operable with one hand to dispense soap on the palm of that hand (see Figure 42).

9.6 WASHROOMS (cont'd)

6.2.4.4 Towel dispensers/hand dryers

A towel dispenser and/or hand dryer adjacent to the accessible lavatory shall be

- located within a 500 mm reach of a person seated at the lavatory;
- no higher than 1100 mm; and
- operable with one hand to dispense towels or activate hand dryer (see Figure 42).

Figure 42
Washroom accessory heights
(See Clauses 6.2.4.2 – 6.2.4.4.)

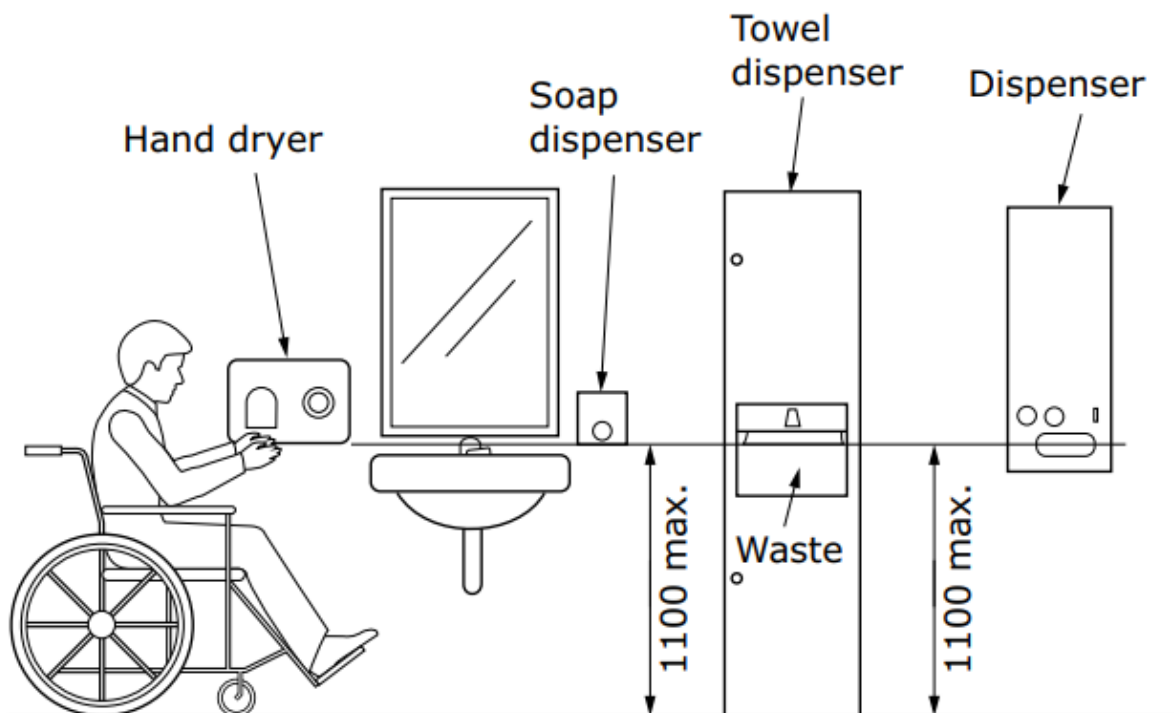

9.6 WASHROOMS (cont'd)

6.2.5 Grab bars

6.2.5.1 Size and spacing

A grab bar shall

- a) be slip-resistant;
- b) have a diameter between 30 and 40 mm;
- c) where mounted adjacent to a wall, have a space between 35 and 45 mm between the wall and the grab bar; and
- d) not rotate within its fittings.

6.2.5.2 Structural strength

A grab bar shall be installed to resist a force of at least 1.3 kN applied in any direction.

6.2.5.3 Surfaces

A grab bar and adjacent surfaces shall be free of any sharp or abrasive elements.

6.2.6 Toilets

6.2.6.1 Toilet fixtures

A toilet fixture shall have

- a) the top of the seat between 430 and 485 mm from the floor (see Figure 43);
- b) no spring-activated seat;
- c) a back support where there is no seat lid or tank; and
- d) where there is a tank, a tank lid that is securely attached.

6.2.6.2 Location

A toilet shall

- a) be located with its centreline between 460 and 480 mm from an adjacent wall (see Figure 43); and
- b) have a clear transfer space at least 900 mm wide × 1500 mm long on its open side, the width measured from the edge of the toilet bowl (see Figure 44).

6.2.6.3 Controls

Flush controls shall

- a) be automatically activated; or
- b) be hand-operated by a device that
 - i) complies with Clauses 4.2.1, 4.2.3, 4.2.4, 4.2.5, and 4.2.8; and
 - ii) is not more than 350 mm from the transfer space side of the toilet.

9.6 WASHROOMS (cont'd)

6.2.6.4 Grab bars

Grab bars that comply with Clause 6.2.5 shall be provided as follows:

- a) There shall be one L-shaped grab bar that is
 - i) mounted on the side wall closest to the toilet; and
 - ii) has horizontal and vertical components that are at least 760 mm long, such that
 - 1) the horizontal component is 760 to 850 mm above the floor; and
 - 2) the vertical component is 150 mm in front of the toilet.
- b) There shall be a horizontal grab bar that is
 - i) mounted on the rear wall (see Figure 43);
 - ii) centred over the toilet (see Figure 43);
 - iii) not less than 600 mm long (see Figure 43); and
 - iv) mounted at the same height as the grab bar on the side wall, except where the toilet has an attached water tank, in which case the grab bar shall be mounted 100 mm above the top of the tank.

6.2.6.5 Toilet paper dispensers

A toilet paper dispenser shall be located

- a) such that the closest edge of the dispenser is 300 mm from the front of the toilet; and
- b) at a height between 600 and 800 mm from the floor.

Figure 43
Toilet

(See Clauses 6.2.6.1, 6.2.6.2, and 6.2.6.4.)

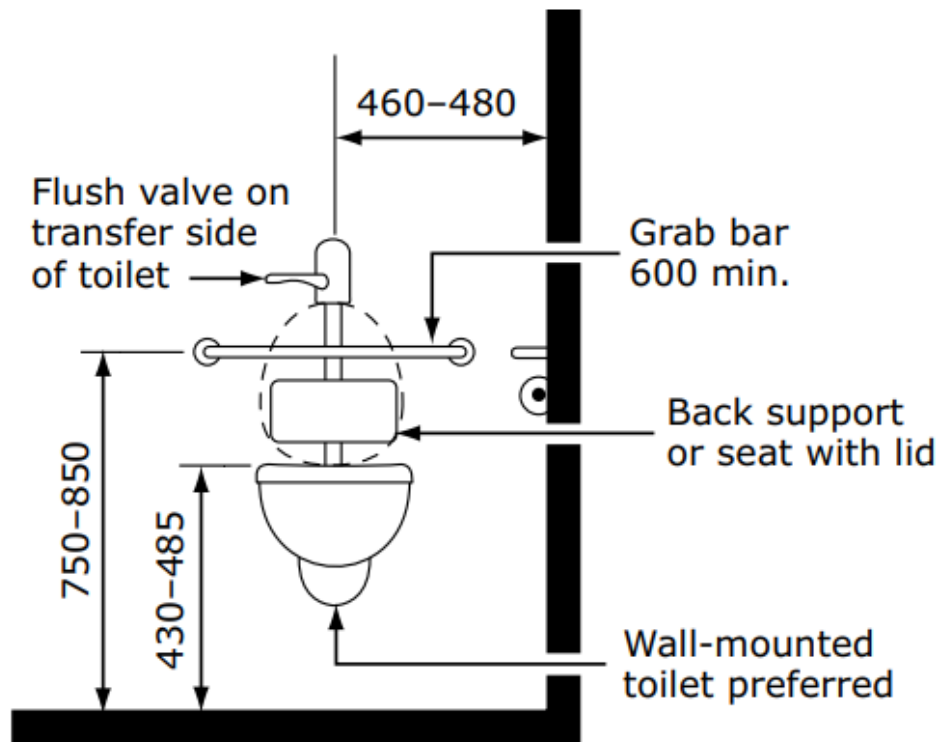

Note: All dimensions are in mm.

6.2.7 Toilet stalls

6.2.7.1 Accessible toilet stalls

An accessible toilet stall shall have

- a) internal dimensions at least 1600 mm wide × 1500 mm deep (see Figure 44);
- b) a toilet complying with Clause 6.2.6;
- c) a hook on a side wall
 - i) mounted not more than 1200 mm from the floor; and
 - ii) projecting not more than 40 mm from the wall.

9.6 WASHROOMS (cont'd)

6.2.7.2 Toilet stall doors

Toilet stall doors shall

- a) provide a clear opening of at least 850 mm with the door in the open position;
- b) be aligned with the transfer space adjacent to the toilet, unless the internal dimensions of the toilet stall exceed the minimum values specified in Clause 6.2.7.1 a), such that there is additional manoeuvring area between the door and the transfer space (see Figures 40 and 44);
- c) have a "D"-type door pull at least 140 mm long, mounted horizontally on the inside of an outswinging door
 - i) with its centreline located between 200 and 300 mm from the hinge edge; and
 - ii) at a height between 800 and 1000 mm from the floor (see Figure 44);
- d) have a "D"-type door pull at least 140 mm long, mounted horizontally on the outside
 - i) with its centreline located between 120 and 220 mm from the latch edge of the door; and
 - ii) at a height between 800 and 1000 mm from the floor;
- e) be self-closing so that when at rest, the door will be ajar not more than 50 mm beyond the jamb;
- f) be latched from the inside by a device that complies with Clause 4.2.4; and
- g) have a clear area at least 1700 × 1700 mm in front of the stall that complies with Clause 5.2.2 (see Figure 40).

9.6 WASHROOMS (cont'd)

Figure 44
Toilet stall

(See Clauses 6.2.6.2, 6.2.6.4, 6.2.7.1, 6.2.7.2, and 6.3.2.)

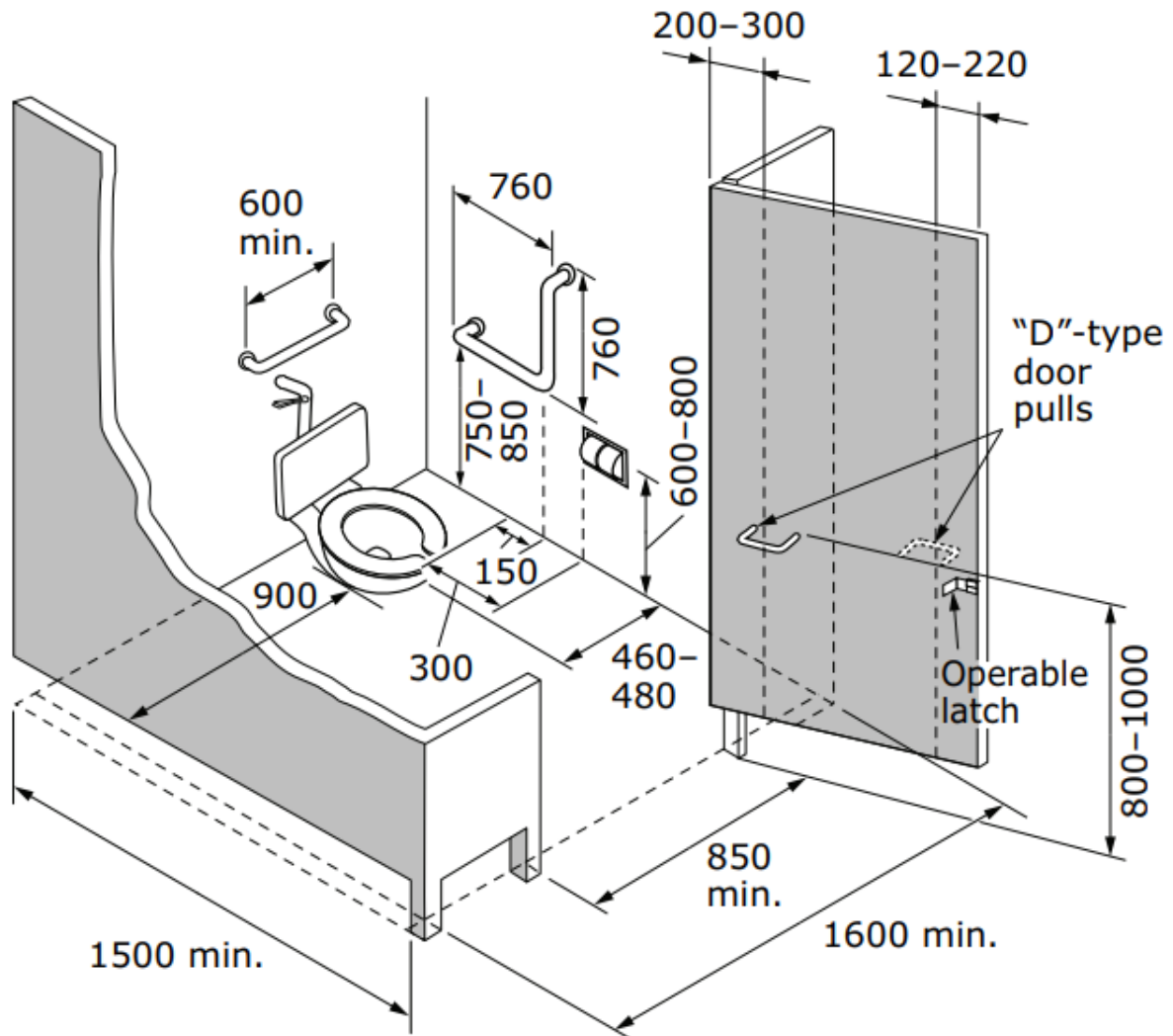

Note: All dimensions are in mm.

9.6 WASHROOMS (cont'd)

6.2.7.3 Toilet stalls for users with limited mobility

A toilet stall for users with limited mobility (see Figure 45) shall be a standard-sized stall equipped with

- a) horizontal grab bars, one on each side of the fixture, that
 - i) comply with Clause 6.2.5;
 - ii) are at a height between 750 and 850 mm from the floor;
 - iii) begin not more than 300 mm from the rear wall; and
 - iv) extend at least 450 mm in front of the toilet seat;
- b) a toilet fixture that complies with Clause 6.2.6.1;
- c) a door that
 - i) opens outward;
 - ii) is self-closing so that when at rest, the door will be ajar not more than 50 mm beyond the jamb; and
 - iii) is latched from the inside by a device that complies with Clause 4.2.4; and
- d) a sign on the door that
 - i) complies with Clause 4.5; and
 - ii) indicates that the stall is suitable for users who may require grab bar assistance.

Figure 45
Toilet stall for users with limited mobility
(See Clause 6.2.7.3.)

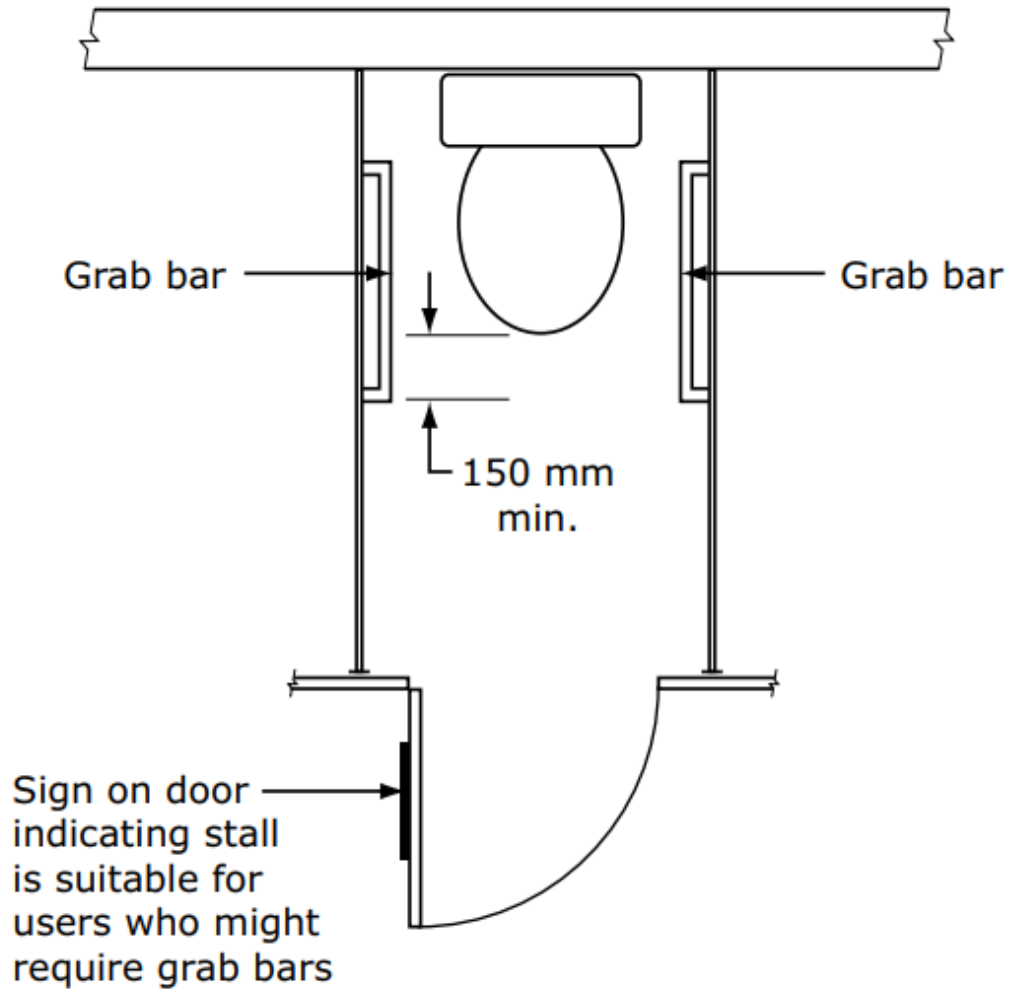

Note: All dimensions are in mm.

6.3 Universal washrooms

6.3.1 General

6.3.1.1

Where a universal washroom containing a single toilet and lavatory is provided, it shall

- a) provide a clear area of at least 1700 × 1700 mm;
- b) have a lavatory that complies with Clause 6.2.3;
- c) have a toilet that complies with Clause 6.2.6; and
- d) be identified by a sign that
 - i) complies with Clause 4.5.6; and
 - ii) shows a male and female pictogram or gender-neutral pictogram and the International Symbol of Access (see Figures 12 and 13).

6.3.1.2

A universal washroom shall be equipped with an emergency call system that can be actuated by a control located inside the washroom, which will activate audible and visual signal devices inside and outside of the washroom. A sign having lettering at least 25 mm and posted above the emergency button shall indicate that signal devices will activate when the button is pushed.

There shall be signage posted outside the washroom with instructions to passersby on how to retrieve the washroom key, open the door, and render assistance in the event of an emergency.

If the door has an electric strike, it shall be automatically released when the alarm button is pressed so that assistance can be provided.

9.6 WASHROOMS (cont'd)

6.3.2 Washroom door

A door to a universal washroom shall

- a) comply with Clause 5.2;
- b) have a locking mechanism on the inside that complies with Clause 4.2.4;
- c) have a power-assisted door opener; and
- d) be capable of being unlocked from the outside in an emergency situation.

6.3.3 Washroom accessories

Accessories in a universal washroom shall

- a) comply with Clause 6.2.4;
- b) include a shelf or counter at least 200 × 400 mm; and
- c) include a coat hook mounted on a side wall
 - i) at a height not more than 1200 mm from the floor; and
 - ii) protruding not more than 40 mm from the wall.

Figure 47
Universal washroom
(See Clause 6.3.1.1.)

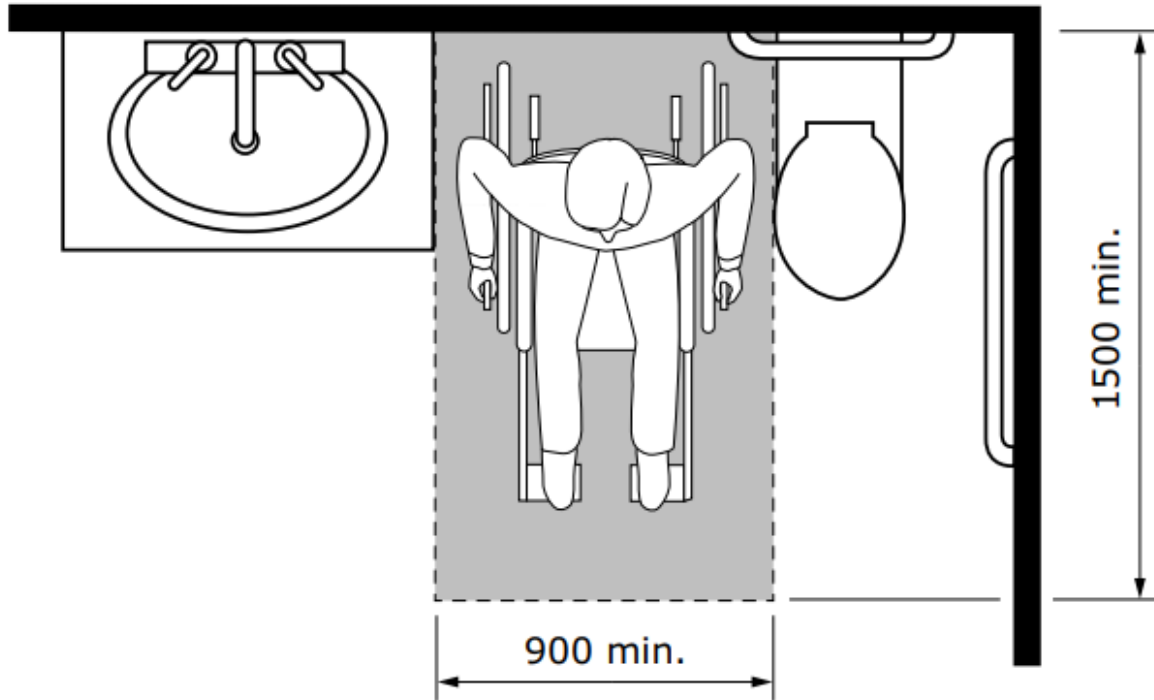

a) Clear transfer space beside toilet

Figure 47 (Concluded)

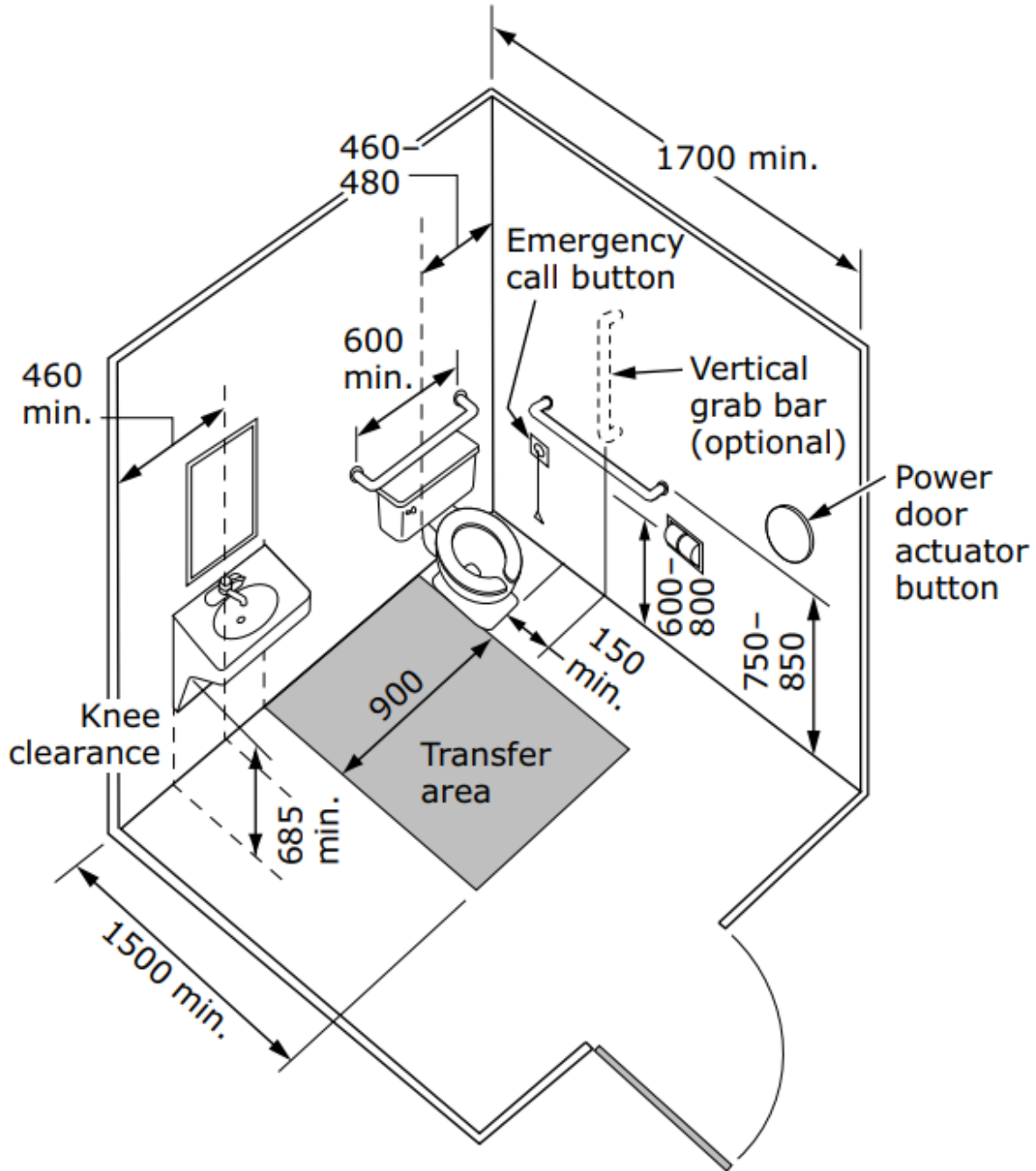

b) Example layout

Note: All dimensions are in mm.

9.7 SEATING

As the Built Environment Standard for the Nova Scotia Accessibility Act (Bill 59) is still under development we recommended following the standard set out by the National Standard of Canada in B651-18, Accessible Design for the Built Environment. For all aspects of seating, we recommend the Truro-Colchester Region refer to section 6.7 of the National Standard for examples, some of which, we have included below.

6.7 Seating

6.7.1 Spaces at tables and counters

6.7.1.1 Floor area

A seating space for persons using a wheeled mobility device, such as that provided at counters, tables, or work surfaces, shall have

- a) a clear floor area not less than 800 × 1350 mm [see Figure 54 a) and b)]; and
- b) adequate manoeuvring space to approach it.

6.7.1.2 Height

A table or counter surface shall be at a height between 730 and 860 mm from the floor.

6.7.1.3 Knee clearance

Where a forward approach is used, the knee clearance shall be at least 800 mm wide × 480 mm deep × 685 mm high, which may overlap the clear floor area by not more than 480 mm [see Figure 54 a)].

Figure 54
Seating at tables and counters
(See Clauses 6.7.1.1 and 6.7.1.3.)

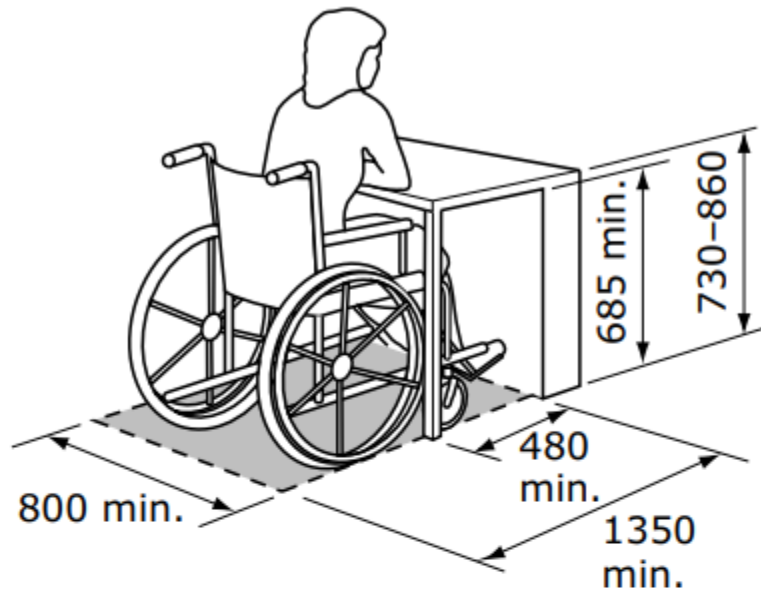

a)

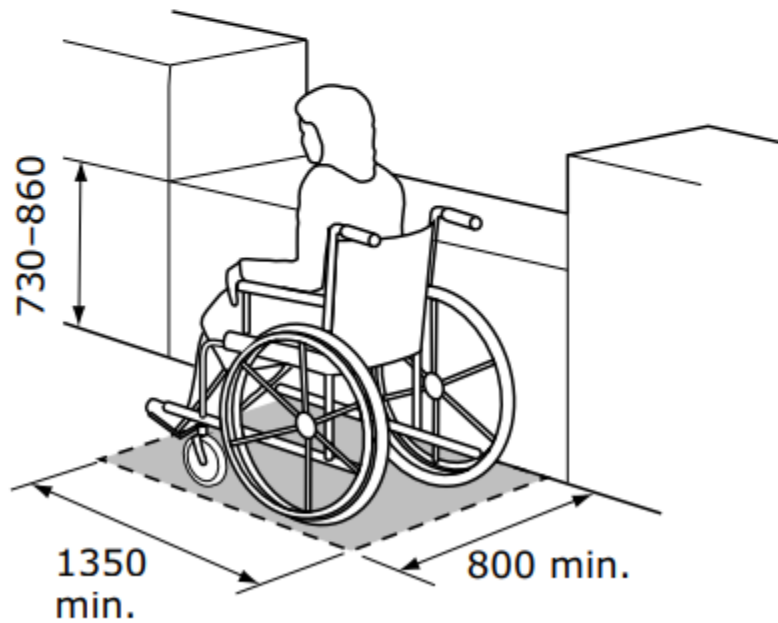

b)

Note: All dimensions are in mm.

9.8 ELEVATORS

As the Built Environment Standard for the Nova Scotia Accessibility Act (Bill 59) is still under development we recommended following the standard set out by the National Standard of Canada in B651-18, Accessible Design for the Built Environment. However, the National Standard of Canada does not provide information around elevators. For all aspects of elevators, we recommend the Truro-Colchester Region refer to the bi-national standard ASME A17.1-2016/CSA B44-16, set out as a joint effort between the American Society of Mechanical Engineers and the Canadian Standards Association. This standard is for all jurisdictions enforcing the National Building Code of Canada. We have included the document below for reference.

NONMANDATORY APPENDIX E ELEVATOR REQUIREMENTS FOR PERSONS WITH PHYSICAL DISABILITIES IN JURISDICTIONS ENFORCING THE NBCC

INTRODUCTION

This Appendix was developed and approved by the CSA B44 Technical Committee. The ASME A17 Standards Committee, in the spirit of harmonization, authorized the publication of this Appendix.

This Appendix is not a mandatory part of this Code; however, it is provided for reference in order to comply with the requirements of the NBCC.

E-1 SCOPE

This Appendix contains requirements intended to make passenger elevators usable by persons with physical disabilities in jurisdictions enforcing the NBCC. These requirements are in addition to, or modifications of, certain requirements specified elsewhere in this Code. Elevators shall be passenger elevators as classified by ASME A17.1/CSA B44. Elevator operation shall be automatic.

E-2 DEFINITIONS

destination-oriented elevator system: an elevator system that provides lobby controls for the selection of destination floors, lobby indicators designating which elevator to board, and a car indicator designating the floors at which the car will stop.

elevator car call sequential step scanning: a technology used to enter a car call by means of an up or down floor selection button.

physical disability: a disability resulting in a mobility or sensory impairment.

variable message signs (VMS): electronic signs that have a message with the capacity to change by means of scrolling, streaming, or paging across a background.

variable message sign (VMS) characters: characters of an electronic sign composed of pixels in an array.

E-3 LEVELING

Each car shall automatically stop and maintain position at floor landings within a tolerance of 13 mm ($\frac{1}{2}$ in.) under rated loading to zero loading conditions.

E-4 DOOR OPERATION

Power-operated horizontally sliding car and landing doors opened and closed by automatic means shall be provided.

E-5 DOOR SIZE

The clear width of elevator doors shall comply with Table E-5-1.

E-6 DOOR PROTECTIVE AND REOPENING DEVICE

E-6.1 Doors shall be provided with a door reopening device that automatically stops and reopens the car door and landing door if the door becomes obstructed by an object or person. This reopening device shall also be capable of sensing an object or person in the path of a closing door at 125 mm \pm 25 mm (5 in. \pm 1 in.) and 735 mm \pm 25 mm (29 in. \pm 1 in.) above the floor without requiring contact for activation, although contact may occur before the door reverses.

E-6.2 Door reopening devices shall remain effective for a period of not less than 20 s.

E-7 DOOR TIMING FOR HALL AND CAR CALLS

E-7.1 The minimum acceptable time from notification that a car is answering a call until the doors of that car start to close shall be calculated from the following equation, but shall not be less than 5 s:

$$T = D/(455 \text{ mm/s})$$

or

$$T = D/(1.5 \text{ ft/s})$$

where T equals the total time in seconds and D equals the distance (in millimeters or feet) from the point in the lobby or corridor 1525 mm (60 in.) directly in front of the farthest call button controlling that car to the centerline of its hoistway door.

E-7.2 For cars with in-car lanterns, T shall begin when the signal is visible from the point 1525 mm (60 in.) directly in front of the farthest hall call button and the audible signal is sounded.

9.8 ELEVATORS (cont'd)

Table E-5-1 Minimum Dimensions of Elevator Cars

Door Location	Door Clear Width, mm	Inside Car, Side to Side, mm	Inside Car, Back Wall to Front Return, mm	Inside Car, Wall to Inside Face of Door, mm
Centered	1065	2030	1295	1370
Side (off-center)	915 ²	1725	1295	1370
Any	915 ²	1370	2030	2030
Any	915 ²	1525	1525	1525

GENERAL NOTES:

(a) This Table is based on Tables 407.2.8 and 407.4.1 in ANSI/ICC A117.1, metric values only.

(b) A tolerance of -16 mm shall be permitted.

E-7.3 Elevator doors shall remain fully open in response to a car call for 3 s minimum.

E-8 INSIDE DIMENSIONS OF ELEVATOR CARS

E-8.1 The inside dimensions of elevator cars shall comply with [Table E-5-1](#).

E-8.2 Other car configurations that provide a 915 mm (36 in.) minimum clear door width and a circular space with a minimum diameter of 1525 mm (60 in.) with the door closed are permitted.

E-9 CAR CONTROLS

E-9.1 Features. Car controls shall have the features as specified in [Clauses E-9.2 through E-9.4](#).

E-9.2 Height. Buttons with floor designations shall be located a maximum of 1220 mm (48 in.) above the floor or ground measured to the centerline of the buttons. Emergency control buttons, including emergency alarms where provided, shall be grouped at the bottom of the panel. Emergency control buttons shall have their centerlines 890 mm (35 in.) minimum above the floor or ground.

E-9.3 Buttons

E-9.3.1 Button Dimensions. Buttons shall be 19 mm (0.75 in.) minimum in their smallest dimension. Buttons or surrounding button collars shall be raised a minimum of 1.5 mm (0.06 in.).

E-9.3.2 Button Arrangement. Buttons shall be arranged with numbers in ascending order. Floors shall be designated ... -4, -3, -2, -1, 0, 1, 2, 3, 4, etc., with floors below the main entry floor designated with negative numbers. Numbers shall be permitted to be omitted, provided the remaining numbers are in sequence. Where a telephone keypad arrangement is used, the number key (#) shall be used to enter the minus symbol (“-”). When two or more columns of buttons are provided, they shall read from left to right.

E-9.3.2.1 Where existing building floor designations differ from the arrangement required by [Clause E-9.3.2](#) or are alphanumeric, a new operating panel shall be permitted to use such existing building floor designations.

E-9.3.3 Button Characteristics

E-9.3.3.1 Control buttons shall be identified by raised characters and Braille complying with [Clause E-20](#).

E-9.3.3.2 Raised character and Braille designations shall be placed immediately to the left of the button to which the designations apply. When a negative number is used to indicate a negative floor, the Braille designation shall be a cell with the dots 3 and 6 followed by the ordinal number.

E-9.3.4 Control Button. The control button for the main entry floor, and control buttons other than remaining buttons with floor designations, shall be identified with raised symbols and Braille as shown in [Table 2.26.12.1](#).

The location and size of Braille, where required, shall comply with [Table 2.26.12.1](#).

E-9.3.5 Visible Indicators. Buttons with floor designations shall be provided with visible indicators to show that a call has been registered. The visible indication shall extinguish when the car arrives at the designated floor.

E-9.3.6 Elevator Car Call Sequential Step Scanning. Elevator car call sequential step scanning shall be provided where car control buttons are provided more than 1220 mm (48 in.) above the floor. Floor selection shall be accomplished by applying momentary or constant pressure to the up or down scan button. The up scan button shall sequentially select floors above the current floor. The down scan button shall sequentially select floors below the current floor. When pressure is removed from the up or down scan button for more than 2 s, the last floor selected shall be registered as a car call. The up and down scan buttons shall be located adjacent to or immediately above the emergency control buttons.

9.8 ELEVATORS (cont'd)

E-9.4 Telephone-Style Keypads. Telephone-style keypads shall be in a standard telephone keypad arrangement. Call buttons shall be 19 mm (0.75 in.) minimum in their smallest dimension. Buttons shall be raised a minimum of 1.5 mm (0.06 in.). Braille shall not be required. Characters shall be 13 mm (0.5 in.) minimum in height and otherwise conform to [Clause E-20.4](#). The number five key shall have a single raised dot. The dot shall be 3.00 mm to 3.05 mm (0.118 in. to 0.12 in.) base diameter and in other aspects conform to [Table E-20.4.3-1](#). Characters shall be centered on the corresponding keypad button. A display shall be provided in the car with visible indicators to show registered car destinations. The visible indication shall extinguish when the call has been answered. A standard five-pointed star shall be used to indicate the main entry floor.

E-10 CAR POSITION INDICATORS

E-10.1 General. In elevator cars, both audible and visible car floor location indicators shall be provided to identify the floor location of the car.

E-10.2 Visible Indicators. Indicators shall be located above the car control panel or above the door. Numerals shall be 16 mm (0.63 in.) minimum in height.

E-10.2.1 Floor Arrival. To indicate a car passing a floor and when a car stops at a floor served by the elevator, the corresponding character shall illuminate.

E-10.3 Audible Indicators

E-10.3.1 The audible signal shall be 10 dBA minimum above ambient, but shall not exceed 80 dBA maximum, measured at the annunciator. The signal shall be an automatic verbal announcement that announces the floor at which the car is about to stop. The verbal announcement indicating the floor shall be completed prior to the initiation of the door opening. The verbal annunciator shall have a frequency of 300 Hz minimum and 3 000 Hz maximum.

E-10.3.2 For elevators, other than destination-oriented elevators, that have a rated speed of 1 m/s (200 ft/min) or less, where the verbal annunciator is not provided, an audible signal with a frequency of 1 500 Hz maximum that sounds as the car passes or stops at a floor served by the elevator shall be permitted.

E-11 EMERGENCY COMMUNICATIONS

E-11.1 General. Emergency two-way communication systems between the elevator car and a point outside the hoistway shall comply with [2.27.1](#). The operable parts of a two-way communication system shall be located between 380 mm (15 in.) and 1 220 mm (48 in.) from the floor.

E-11.2 Instructions. Operating instructions required by [2.27.1](#) shall be presented in both tactile and visual form.

E-12 FLOOR SURFACES

Floor surfaces in elevator cars shall have a firm, stable, and slip-resistant surface that permits easy movement of wheelchairs. Carpet pile height shall be 13 mm (0.5 in.) maximum.

E-13 HANDRAILS

Handrails shall be provided on all nonaccess walls. The top of the gripping surfaces of the handrails shall be at a height of 800 mm to 920 mm (31.5 in. to 36.2 in.), with a space of 35 mm to 45 mm (1.4 in. to 1.8 in.) between the handrails and wall.

E-14 ILLUMINATION LEVELS

The level of illumination at the car controls shall be 100 lx (10 fc) minimum.

E-15 HALL BUTTONS

E-15.1 Hall buttons and keypad buttons in elevator lobbies and halls shall be located vertically between 890 mm (35 in.) and 1 220 mm (48 in.) above the floor, measured to the centerline of the respective button.

E-15.2 A clear floor space of 760 mm (30 in.) minimum by 1 220 mm (48 in.) minimum shall be provided at hall buttons and keypads.

E-15.3 Hall buttons shall be 19 mm (0.75 in.) minimum in the smallest dimension.

E-15.4 Hall buttons shall have visual signals to indicate when each call is registered and when each call is answered. Call buttons shall provide an audible signal or mechanical motion of the button to indicate when each call is registered.

E-15.5 The hall button that designates the UP direction shall be located above the button that designates the DOWN direction. Buttons or surrounding button collars shall be raised a minimum of 1.5 mm (0.06 in.). Objects located beneath hall buttons shall protrude 25 mm (1 in.) maximum.

E-15.6 Keypads. Where keypads are provided, they shall comply with [Clause E-9.4](#).

E-16 HALL OR IN-CAR SIGNALS

E-16.1 General. A visible and audible signal shall be provided at each hoistway entrance to indicate which car is answering a call and its direction of travel, except that signals in cars, visible from the floor area adjacent to the hall call buttons and complying with requirements of [Clauses E-16.2](#) and [E-16.3](#) shall be permitted.

9.8 ELEVATORS (cont'd)

E-16.2 Audible Signals. Audible signals shall sound once for the UP direction and twice for the DOWN direction, or shall have verbal annunciators that state the word UP or DOWN. Audible signals shall have a frequency of 1500 Hz maximum. Verbal annunciators shall have a frequency of 300 Hz minimum and 3000 Hz maximum. The audible signal or verbal annunciator shall be 10 dBA minimum above ambient, but shall not exceed 80 dBA maximum, measured at the hall call button.

E-16.3 Visible Signals

E-16.3.1 Height. Hall signal fixtures shall be 1830 mm (72 in.) minimum above the floor or ground, measured to the centerline of the fixture.

E-16.3.2 Size. The visible signal elements shall be 60 mm (2.36 in.) minimum between the uppermost and lowest edges of the illuminated shape measured vertically.

E-16.3.3 Visibility. Signals shall be visible from the floor area adjacent to the hall button.

E-17 FLOOR/CAR DESIGNATIONS

Raised character and Braille floor designations shall be provided on both jambs of elevator hoistway entrances and shall be centered at 1525 mm (60 in.) above the floor, measured from the baseline of the characters. A raised star placed immediately to the left of the floor designation shall also be provided on both jambs at the main entry level. Such characters shall be 50 mm (2 in.) high and shall comply with [Clauses E-20.2](#) and [E-20.3](#).

E-18 DESTINATION-ORIENTED ELEVATORS

E-18.1 General. Destination-oriented elevators shall comply with [Clauses E-3](#) through [E-8](#), [E-11](#), [E-12](#), [E-14](#), [E-17](#), and [E-18.2](#) through [E-18.6](#).

E-18.2 Call Buttons. Call buttons shall be 890 mm minimum and 1220 mm maximum (35 in. minimum and 48 in. maximum) above the floor or ground, measured to the centerline of the buttons. A clear floor or ground space of 760 mm × 1220 mm (30 in. × 48 in.) shall be provided. Call buttons shall be 19 mm (0.75 in.) minimum in their smallest dimension. Buttons shall be raised a minimum of 1.5 mm (0.06 in.). Objects beneath hall call buttons shall protrude 25 mm (1 in.) maximum into the clear floor or ground space. Destination-oriented elevator systems shall have a keypad or other means for the entry of destination information. Keypads, if provided, shall be in a standard telephone keypad arrangement, and buttons shall be identified by visual characters complying with [Clause E-20.2](#). Characters shall be centered on the corresponding keypad button. The number five key shall have a single raised dot. The dot shall be 3.00 mm to 3.05 mm (0.118 in. to 0.12 in.) base diameter, and in other aspects comply with [Table E-20.4.3-1](#). Destination-oriented elevator

systems shall be provided with a visual signal and audible tones and verbal announcements to indicate which car is responding to a call. The audible tones and verbal announcements shall be activated by pressing a function button. The function button shall be identified by the international symbol for accessibility and a raised indication (see [Figure E-20.6.3](#)). The symbol shall be 16 mm (0.63 in.) in height and be a visual character complying with [Clause E-20.2](#). The indication shall be three raised dots, spaced 6 mm (0.25 in.) at base diameter, in the form of an equilateral triangle. The function button shall be located immediately below the keypad arrangement or floor buttons. A display shall be provided in the car with visible indicators to show registered car destinations.

E-18.3 Hall Signals

E-18.3.1 General. Destination-oriented elevators shall be provided with a visible signal and audible tones and verbal announcements to indicate which car is responding to a call. The signals shall be the same as those given at the call button or call button keypad, if provided. Each elevator in a bank shall have audible and visible means for differentiation.

E-18.3.2 Visible Signals

E-18.3.2.1 Height. Hall signal fixtures shall be 1830 mm (72 in.) minimum above the floor or ground, measured to the centerline of the fixture.

E-18.3.2.2 Size. The visible signal elements shall be 60 mm (2.36 in.) minimum in their smallest dimension.

E-18.3.2.3 Visibility. Signals shall be visible from the floor area adjacent to the hoistway entrance.

E-18.4 Car Controls. Emergency controls, including emergency alarms where provided, shall have centerlines that are 890 mm minimum and 1220 mm maximum (35 in. minimum and 48 in. maximum) above the floor or ground. Buttons shall be 19 mm (0.75 in.) minimum in their smallest dimension. Buttons shall be raised a minimum of 1.5 mm (0.06 in.).

E-18.5 Car Position Indicators

E-18.5.1 General. In elevator cars, audible and visible car location indicators shall be provided.

E-18.5.2 Visible Indicators. A display shall be provided in the car with visible indicators to show car destinations. Numerals shall be 16 mm (0.63 in.) high minimum. The visible indicators shall extinguish when the car arrives at the designated floor.

E-18.5.3 Audible Indicators. An automatic verbal announcement that announces the floor at which the car is about to stop shall be provided. The announcement shall be 10 dBA minimum above ambient and 80 dBA maximum, measured at the annunciator. The verbal

9.8 ELEVATORS (cont'd)

announcement indicating the floor shall be completed prior to the initiation of the door opening. The verbal annunciator shall have a frequency of 300 Hz minimum and 3000 Hz maximum.

E-18.6 Elevator Car Identification. In addition to the tactile signs required by [Clause E-17](#), a raised elevator car identification shall be placed immediately below the hoistway entrance floor designation. The characters shall be 50 mm (2 in.) high and shall comply with [Clauses E-20.2](#) and [E-20.3](#).

E-18.7 Destination-Oriented Elevators. Destination-oriented elevators shall not be required to comply with [Clause E-7.1](#).

E-19 LIMITED-USE/LIMITED-APPLICATION ELEVATORS

Limited-use/limited-application elevators shall comply with [Clauses E-1](#), [E-3](#), [E-5](#) through [E-17](#), and [E-19](#).

E-19.1 Elevator Door Requirements. Elevator hoistway doors shall comply with [Clause E-19.1](#).

E-19.1.1 Sliding Doors. Sliding hoistway doors shall comply with [Clause E-4](#).

E-19.1.2 Swinging Doors. Swinging hoistway doors shall open and close automatically and shall comply with [Clause E-19.1.2](#). The clear floor space for hall call buttons shall be located beyond the arc of the door swing.

E-19.1.2.1 Power Operation. Swinging doors shall be power-operated and shall comply with ANSI/BHMA A156.19.

E-19.1.2.2 Duration. Power-operated swinging doors shall remain open for 20 s minimum when activated.

E-19.1.3 Door Location and Width. Car doors shall comply with [Clause E-19.1.3](#).

E-19.1.3.1 Cars With a Single Door or With Doors on Opposite Ends. Car doors shall be positioned at the narrow end of cars with a single door and on cars with doors on opposite ends. Doors shall provide a clear opening width of 815 mm (32 in.) minimum.

E-19.1.3.2 Cars With Doors on Adjacent Sides

E-19.1.3.2.1 Car doors shall be permitted to be located on adjacent sides of cars that provide a 1.67 m² (18 ft²) platform. Doors located on the narrow end of cars shall provide a clear opening width of 915 mm (36 in.) minimum. Doors located on the long side shall provide a clear opening width of 1065 mm (42 in.) minimum and shall be located as far as practicable from the door on the narrow end.

E-19.1.3.2.2 Car doors that provide a clear opening width of 915 mm (36 in.) minimum shall be

provide a clear floor area of 1295 mm (51 in.) width and 1295 mm (51 in.) in depth.

E-19.2 Elevator Car Requirements. Elevator cars shall comply with [Clause E-19.2](#).

E-19.2.1 Inside Dimensions. Elevator cars shall provide a clear floor width of 1065 mm (42 in.) minimum. The clear floor area shall not be less than 1.46 m² (15.75 ft²).

E-19.3 Elevator Car Controls, Control panels shall be centered on the longest side wall.

E-20 SIGNS

E-20.1 Accessible signs shall comply with [Clause E-20.2](#). Tactile signs shall contain both raised characters and Braille. Where signs with both visual and raised characters are required, either one sign with both visual and raised characters, or two separate signs, one with visual and one with raised characters, shall be provided.

E-20.2 Visual Characters

E-20.2.1 General

E-20.2.1.1 Visual characters shall comply with either (a) or (b).

(a) Visual characters that also serve as raised characters shall comply with [Clause E-20.3](#).

(b) Visual characters on variable message signs (VMS) signage shall comply with [Clause E-20.7](#).

(c) Visual characters not covered in (a) and (b) shall comply with [Clause E-20.2](#).

E-20.2.1.2 The visual and raised requirements of [E-20.2.1.1\(a\)](#) shall be permitted to be provided by two separate signs that provide corresponding information, provided one sign complies with [Clause E-20.2](#) and the second sign complies with [Clause E-20.3](#).

E-20.2.2 Case. Characters shall be uppercase, lowercase, or a combination of both.

E-20.2.3 Style. Characters shall be conventional in form. Characters shall not be italic, oblique, script, highly decorative, or of other unusual form.

E-20.2.4 Character Height. The uppercase letter "I" shall be used to determine the allowable height of all characters of a font. The uppercase letter "I" of the font shall have a minimum height of 16 mm (0.63 in.), plus 3 mm (0.118 in.) per 305 mm (1 ft) of viewing distance above 1830 mm (6 ft). Viewing distance shall be measured as the horizontal distance between the character and an obstruction preventing further approach toward the sign.

E-20.2.5 Character Width. The uppercase letter "O" shall be used to determine the allowable width of all characters of a font. The width of the uppercase letter "O" shall

9.8 ELEVATORS (cont'd)

be 55% minimum and 110% maximum of the height of the uppercase letter "I" of the font.

E-20.2.6 Stroke Width. The uppercase letter "I" shall be used to determine the allowable stroke width of all characters of a font. The stroke width shall be 10% minimum and 30% maximum of the height of the uppercase "I" of the font.

E-20.2.7 Character Spacing. Spacing shall be measured between the two closest points of adjacent characters within a message, excluding word spaces. Spacing between individual characters shall be 10% minimum and 35% maximum of the character height.

E-20.2.8 Line Spacing. Spacing between the baselines of separate lines of characters within a message shall be 135% minimum to 170% maximum of the character height.

E-20.2.9 Finish and Contrast. Characters and their background shall have a non-glare finish. Characters shall contrast with their background, with either light characters on a dark background or dark characters on a light background.

E-20.3 Raised Characters

E-20.3.1 General. Raised characters shall comply with [Clause E-20.3](#), and shall be duplicated in Braille complying with [Clause E-20.4](#).

E-20.3.2 Depth. Raised characters shall be raised a minimum of 0.8 mm (0.03 in.) above their background.

E-20.3.3 Case. Characters shall be uppercase.

E-20.3.4 Style. Characters shall be sans serif. Characters shall not be italic, oblique, script, highly decorative, or of other unusual form.

E-20.3.5 Character Height

E-20.3.5.1 The uppercase letter "I" shall be used to determine the allowable height of all characters of a font. The uppercase letter "I" of the font, measured vertically from the baseline of the character, shall be 16 mm (0.63 in.) minimum and 50 mm (2 in.) maximum.

E-20.3.5.2 Where separate raised and visual characters with the same information are provided, the height of the raised uppercase letter "I" shall be permitted to be 13 mm (0.5 in.) minimum.

E-20.3.6 Character Width. The uppercase letter "O" shall be used to determine the allowable width of all characters of a font. The width of the uppercase letter "O" of the font shall be 55% minimum and 110% maximum of the height of the uppercase letter "I" of the font.

E-20.3.7 Stroke Width. Raised character stroke width shall comply with [Clause E-20.3.7](#). The uppercase letter "I" of the font shall be used to determine the allowable stroke width of all characters of a font.

E-20.3.7.1 Maximum. The stroke width shall be 15% maximum of the height of the uppercase letter "I" measured at the top surface of the character.

E-20.3.7.2 Minimum. When characters are both visual and raised, the stroke width shall be 10% minimum of the height of the uppercase letter "I."

E-20.3.8 Character Spacing. Character spacing shall be measured between the two closest points of adjacent raised characters within a message, excluding word spaces. Spaces between individual characters shall be 3 mm (0.118 in.) minimum measured at the top surface of the characters, 16 mm (0.63 in.) minimum measured at the base of the characters, and 4 times the raised character stroke width maximum. Characters shall be separated from raised borders and decorative elements 10 mm (0.4 in.) minimum.

E-20.3.9 Line Spacing. Spacing between the baselines of separate lines of raised characters within a message shall be 135% minimum and 170% maximum of the raised character height.

E-20.3.10 Location. Where a sign containing raised characters and Braille is provided at double doors with one active leaf, the sign shall be located on the inactive leaf. Where a sign containing raised characters and Braille is provided at double doors with two active leaves, the sign shall be to the right of the right-hand door. Where there is no wall space on the latch side of a single door, or to the right side of double doors, signs shall be on the nearest adjacent wall. Signs containing raised characters and Braille shall be located so that a clear floor area 455 mm (18 in.) minimum by 455 mm (18 in.) minimum, centered on the raised characters, is provided beyond the arc of any door swing between the closed position and 45 deg open position.

E-20.3.11 Finish and Contrast

E-20.3.11.1 Characters and their background shall have a non-glare finish. Characters shall contrast with their background with either light characters on a dark background or dark characters on a light background.

E-20.3.11.2 Where separate raised characters and visual characters with the same information are provided, raised characters are not required to have non-glare finish or to contrast with their background.

9.9 ACCESSIBLE BOAT LAUNCHES

Seven Design Features of an ADA Accessible Kayak/Canoe Launch

1. Gangway slope: If a ramp drops down to the launch site, it needs to have a modest slope to meet ADA guidelines. The ramp should have 1 foot of length for every inch it drops. Water levels often fluctuate, and gangways allow the system to accommodate the water level change.
2. Handrails: To assist users, handrails down the gangway need to be 36 inches high.
3. Ample room: The deck of the launch site should be big enough to accommodate wheelchairs, watercraft, and other equipment.
4. Step-down bench: In the middle of the floating launch structure is a bench with transition steps so users can work their way down to the kayak. The transfer bench is often made out of stainless steel, which allows the user to slide along each step. Each step is a small drop down. One of our innovative designs yet to be constructed uses large limestone blocks as the transfer bench.
5. The plank: At the end of the bench, a plank slides out over the top of the kayak to provide additional support and allow the user to ease straight down into the kayak.
6. Moving the vessel: Launch decks are often made of composite decking materials for low maintenance and scratch resistance. In the loading area, the kayak or canoe is supported by either rollers or underwater saddles that hold the vessel steady while the user is getting situated into the vessel.
7. More handrails: Additional handrails near the water allow users to work their way down the launch to open water.

USING PADDLE METHOD TO ENTER & EXIT A KAYAK: FLOAT SIZE IMPORTANCE

A low profile floating dock that is at or about the same level as the kayak is vital to using the paddle as a method of entering and exiting.

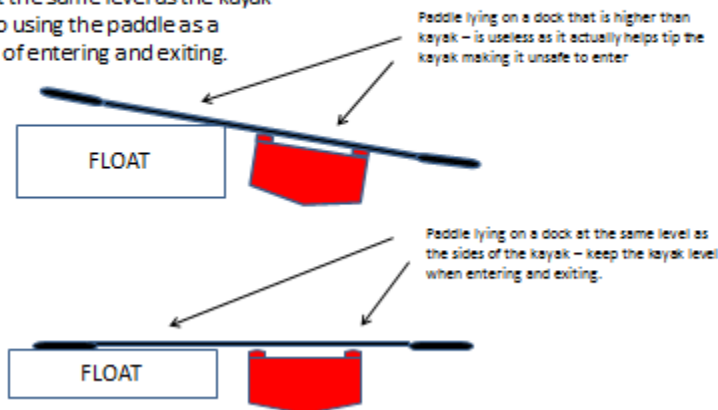



10.0 RESOURCES

10.1 FUNDING AND COMMUNITY BASED RESOURCES

Business Financial Support Options

Small Business ACCESS-Ability Grant Program

Small businesses can apply for a cost-shared grant to make accessibility-related improvements. Improvements can be for clients and customers, for employees, or both.

Five categories of funding

Built Environment:

Removing physical barriers for persons to access business services, by installing ramps, accessible washrooms, door openers, and other projects.

Accessible Communications Services:

Ensuring that all customers, clients, and employees can access information related to a business.

Assistive Devices:

Ensuring that employees and consumers who are person with disabilities have the devices they need to effectively do their jobs and access places of business.

Universal Design Capacity Building:

Training in the field of Universal Design, both for technical services professionals and for persons with disabilities wishing to better understand its value.

Accessible Transportation:

Providing support for businesses to improve access to transportation services.

For more information visit: <https://cch.novascotia.ca/small-business-access-ability-grant-program>

Community ACCESS-Ability Program

The Community ACCESS-Ability Program reflects the Government of Nova Scotia's commitment to persons with disabilities by providing equal opportunity and improved access to community facilities. This program offers cost-shared grants to community groups for accessibility related capital improvements. The grants cover up to two-thirds of the direct and indirect costs of renovations, installations, and/or equipment to a maximum of \$10,000. The sponsoring organization must raise at least one-third of the funding from other sources. Organizations can receive funding for one project per year under the program.

Who can apply?

- Non-profit community organizations
- Municipalities

For more information visit:

<https://cch.novascotia.ca/investing-our-future/community-funding-and-awards/community-access-ability-program>

Training Financial Support

Workplace Innovation and Productivity Skills Incentive

Apply now online at: <https://novascotia.ca/programs/workplace-innovation-productivity-skills-incentive>

Applications for the WIPSI program may be submitted by individual businesses or by an organization/ association on behalf of a group of businesses. WIPSI supplements employer contributions to train full-time staff * (permanently located in Nova Scotia) to

- Improve productivity and profitability
- Increase innovation
- Adapt to new technology, machinery and equipment, or work processes
- Increase inter-provincial and international competitiveness; and Foster workplace diversity.

* Full-time seasonal employees may be considered.

If you identify a training opportunity that would provide new and/or incremental skills to your workforce which will result in

- A new direction or expansion to your core operations; and
- Business and/or sector growth and profitability, you could be eligible for WIPSI funding.

FUNDING

If you are a business in Nova Scotia with less than 50 employees, you may be eligible for up to 100% of your training costs to be covered up to \$10,000. For larger businesses, WIPSI provides up to 50% of direct training costs. WIPSI may also cover other expenses such as travel, books for participants and accommodation costs for persons with disabilities.

Funding Options for Hiring

Resources for employers and government agencies when it comes to accommodations etc.

<https://www.canada.ca/en/employment-social-development/campaigns/hiring-persons-disabilities.html>

START Program (applies to hiring unemployed folks)

<https://novascotia.ca/programs/start/>

Canada Summer Jobs (applications start april 2022)

<https://www.canada.ca/en/employment-social-development/services/funding/canada-summer-jobs.html>

Co-op Education Incentive (Employers offering career-related opportunities for co-op students)

https://novascotia.ca/programs/co-op-education-incentive/?gclid=EA1aIQobChMIsfWxpZ2Y9QIVBZJbCh2rkQBVEAAYASAAEgJNE_D_BwE

Student Summer Skill Incentive (SKILL) (if a non profit wanted to hire a post secondary student for a summer job)

<https://novascotia.ca/programs/student-summer-skills-incentive/>

Energy Training Program (if hiring a student or post secondary if the applicant is in the energy sector)

<https://energy.novascotia.ca/industry-development/energy-training-program>

ECO Canada Youth Placement Program (youth under 30 placement funding in environmentally related positions relating to STEM and natural resources - 3 different streams available)

<https://eco.ca/environmental-professionals/employment-funding-and-job-board/apply-for-job-funding/>

Atlantic Immigration Pilot Program (AIPP) (for highly skilled workers or international graduates to fill labour gaps/needs)

<https://novascotiainmigration.com/help-for-employers/atlantic-immigration-program/>

COVID related - employer can only claim ONE of the below, whichever grants them the most funding

Canada Recovery Hiring Program (only valid till May 7 2022)

<https://www.canada.ca/en/revenue-agency/services/wage-rent-subsidies/recovery-hiring-program.html>

Hardest-Hit Business Recovery Program (HHBRP) (tourism/hospitality related, valid till May 7 2022)

<https://www.canada.ca/en/revenue-agency/services/wage-rent-subsidies/hardest-hit-business-recovery-program.html>

Tourism and Hospitality Recovery Program (THRP) (tourism, hospitality, arts, entertainment and recreation related, valid till May 7 2022)

<https://www.canada.ca/en/revenue-agency/services/wage-rent-subsidies/tourism-hospitality-recovery-program.html>

Database provided by the Sobeyes School of Business at SMU

<https://www.smu.ca/webfiles/FundingOptionsforEmployers.pdf>

Multiple options from wage subsidies to grants for hiring (covers all of Canada, not just ns)

<https://fundinghq.ca/small-business-employee-hiring-funding>

10.2 TRAINING & EDUCATION

Rick Hansen Foundation - Making the Business Case for Accessibility

[Homepage | Rick Hansen Foundation](#)

<https://www.rickhansen.com/sites/default/files/2018-08/cboc-final-report-feb2018-accessible-1.pdf>

Rick Hansen Foundation - Sample Accessibility Improvement Projects

<https://www.rickhansen.com/sites/default/files/downloads/2018-08/sampleaccessibilityimprovementprojects.pdf>

CSA Group B651-18 - ACCESSIBLE DESIGN FOR THE BUILT ENVIRONMENT

https://www.orderline.com/b651-18-accessible-design-for-the-built-environment?gclid=CjwKCAiA1eKB BhBZEiwAX3gql45F1tUoNwvXkt5dISl-AkfBP7gIDvCICf1slWQ8PI7eRXmZ-YhUTRoCF7oQAvD_BwE

Halifax Today: Societys Ableism Exposed

<https://www.halifaxtoday.ca/local-news/societys-ableism-exposed-by-covid-19-pandemic-disability-rights-advocate-2857247>

Diversity & Inclusion Framework, Halifax:

https://www.halifax.ca/sites/default/files/documents/city-hall/Diversity%20%26amp%3B%20Inclusion%20Framework_Final%20Version%20Aug%203_External.pdf

CBC Spark Article and Podcast: Designing for Disability

<https://www.cbc.ca/radio/spark/disabled-people-want-disability-design-not-disability-dongles-1.5353131/designing-for-disability-full-episode-transcript-1.5353287>

Truth and Reconciliation Commission of Canada [Truth and Reconciliation Commission of Canada \(TRC\)](#)

<https://nctr.ca/map.php>

Congress of Aboriginal Peoples - Reconciliation Tool Kit

www.abo-peoples.org/wp-content/uploads/2019/05/WP-Revised-Reconciliation-Toolkit_Digital_May12-compressed.pdf (abo-peoples.org)

The Final Report of the Inquiry into Missing and Murdered Indigenous Women and Girls:

[Final Report | MMIWG \(mmiwg-ffada.ca\)](#) <https://www.mmiwg-ffada.ca/final-report/>

Unconscious Bias and Emotional Intelligence for Leaders Training: In alignment with the identified priorities of Access By Design 2030, we recommend that the Truro-Colchester Region as per capacity building, complete Unconscious Bias/Emotional Intelligence Training. <https://www.reachability.org/train>

Working with Indigenous Peoples - 2018, Acadia University

https://indigenous.acadiau.ca/tl_files/sites/indigenous/Acadia-IndigProtocolsHandbook_27February2018.pdf